

GARAGE CONSTRUCTION

Construction Details:

All perimeter plates in contact with concrete to be pressure treated. Unless concrete floor is poured over an impervious membrane, all interior wall plates also to be pressure treated.

See attached foundation drawing sheet for typical foundation details.

Wall framing may be spaced at 24" O.C. if trusses centered over studs. Utility grade studs may be used if stud spacing is not over 16" O.C. and not over 8 feet in height.

See attached minimum lateral restraint requirements for garage walls with large door openings.

Garages may be of single wall construction if minimum 1/2" exterior plywood panels installed on studs spaced at 24" O.C. or 3/8" minimum exterior plywood installed on studs spaced at 16" O.C. Graded 303 siding panels may be installed without weather resistive barrier between siding and stud. NOTE: CDX sheathing is not exterior grade.

A truss design stamped by a licensed structural engineer must be submitted for owner/site built trusses. All trusses require diagonal and sway bracing per truss manufacturer.

Other Code Requirements:

Under no circumstances shall a private garage have any openings into a room used for sleeping purposes.

Unheated garages are not required to be insulated but it is good practice.

Attached garages are required to be separated from the house by materials approved for one-hour fire-resistive (5/8" Type X GWB) construction installed on the garage side of the wall and a self-closing tight-fitting solid wood door 1 3/8" inches in thickness or a self-closing, tight-fitting door having a fire protection rating of not less than 20 minutes.

ROOF SNOW LOAD REQUIREMENTS

for Lewis County, Washington

These requirements have been determined by the Building Official based on local conditions and the Second Edition of the Snow Load Analysis for Washington published in July 2009, by the Structural Engineers Association of Washington.

City	Actual Elevation	Minimum Roof Snow Load (PSF)
BURNT RIDGE	*1100	50
CENTRALIA	189	25
CHEHALIS	226	25
MINERAL	*1770	(Consult Building Official)
MORTON	940	40
MOSSYROCK	698	30
ONALASKA	505	25
PACKWOOD	*1051	(Consult Building Official)
PE ELL	412	30
RANDLE	880	(Consult Building Official)
TOLEDO	110	25
VADER	175	25
ASHFORD (Paradise Estates)	*1770	(Consult Building Official)
WHITE PASS	*4600	(Consult Building Official)

*For non-residential structures, elevations 1000 feet or over have a frost depth of 18 inches minimum from finish grade to the bottom of the footing. Any elevation less than 1000 feet will have a frost depth of 12 inches. Residential structures will have a frost depth of 18 inches minimum countywide. The Building department will assist you with the calculations for snow load if the actual elevation is known.

WIND LOAD REQUIREMENTS

for Lewis County, Washington

Basic Wind Speed is 85 miles per hour with the exposure determined by the following definitions:

Exposure B has terrain with buildings, forest, or surface irregularities, covering at least 20 percent of the ground level area extending one mile or more from the site.

Exposure C has terrain that is flat and generally open, extending one-half mile or more from the site in any full quadrant.

NOTE: LEWIS COUNTY IS WITHIN SEISMIC D-1.

TYPICAL GARAGE FOUNDATIONS

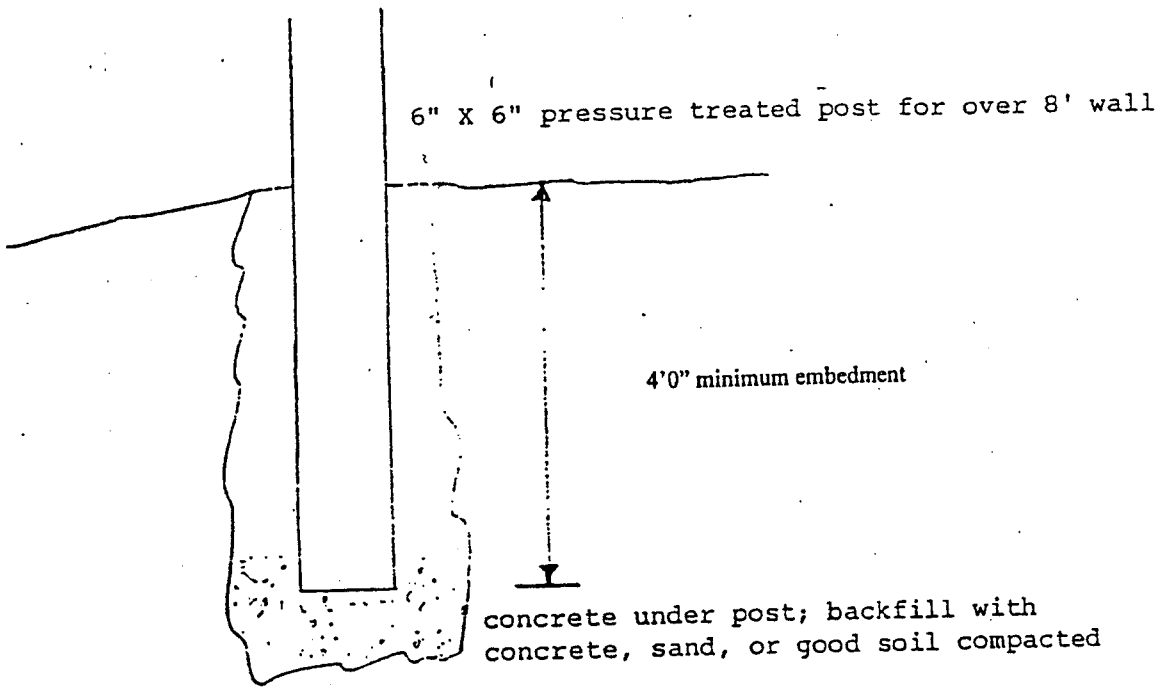
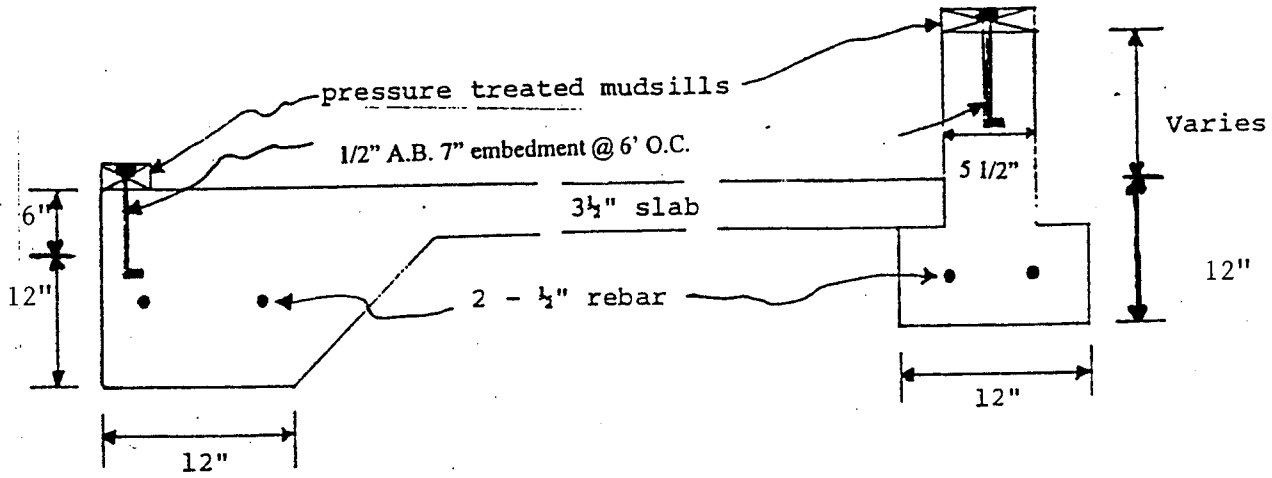

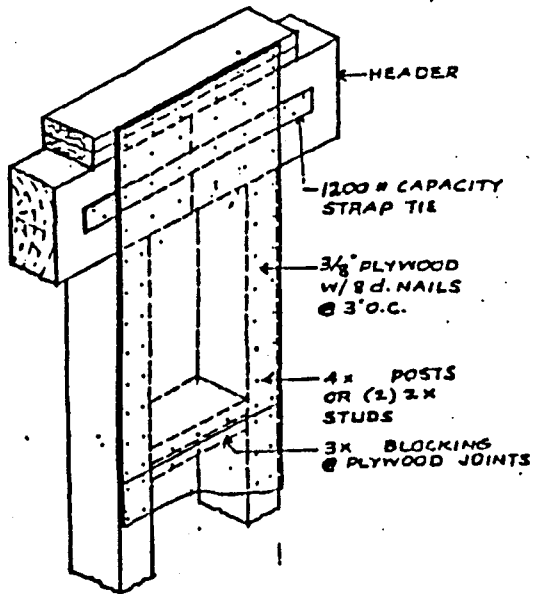

③ HEADER SPLICE

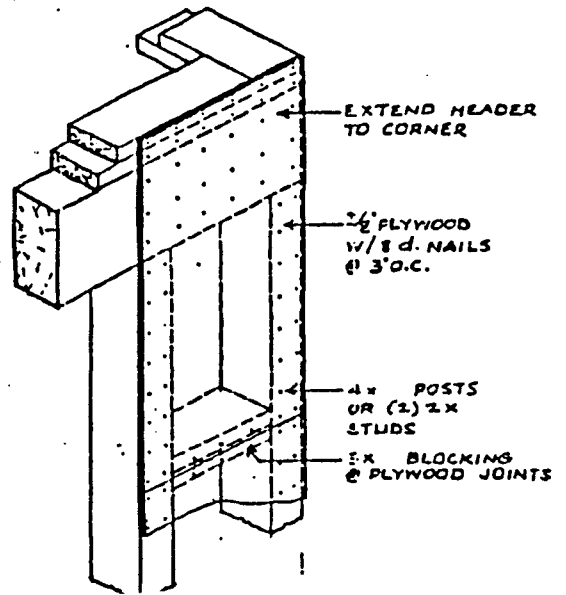

⑤ HEADER AT CORNER

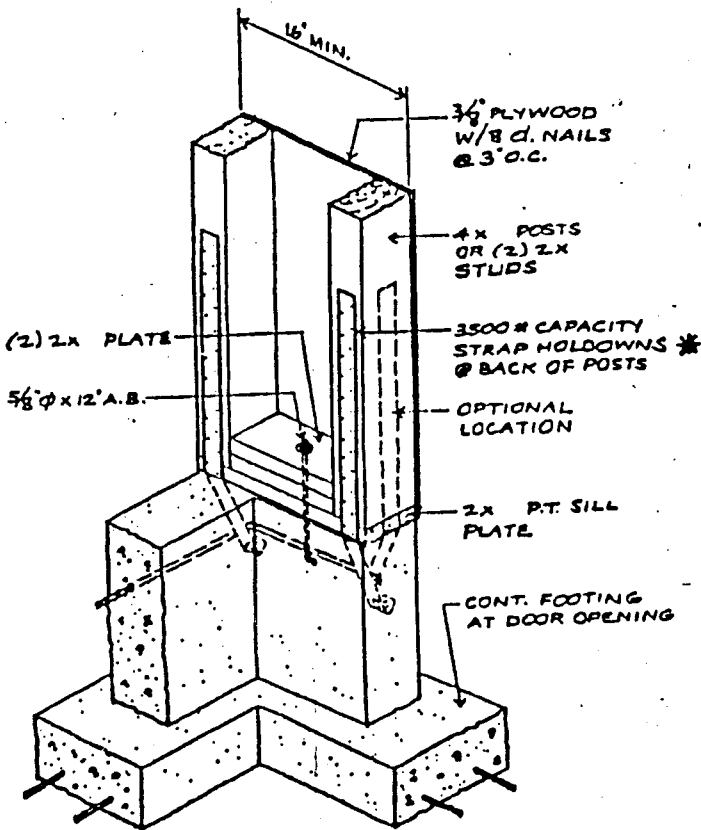

④ STRAP HOLDDOWNS
OPTIONAL LOCATION

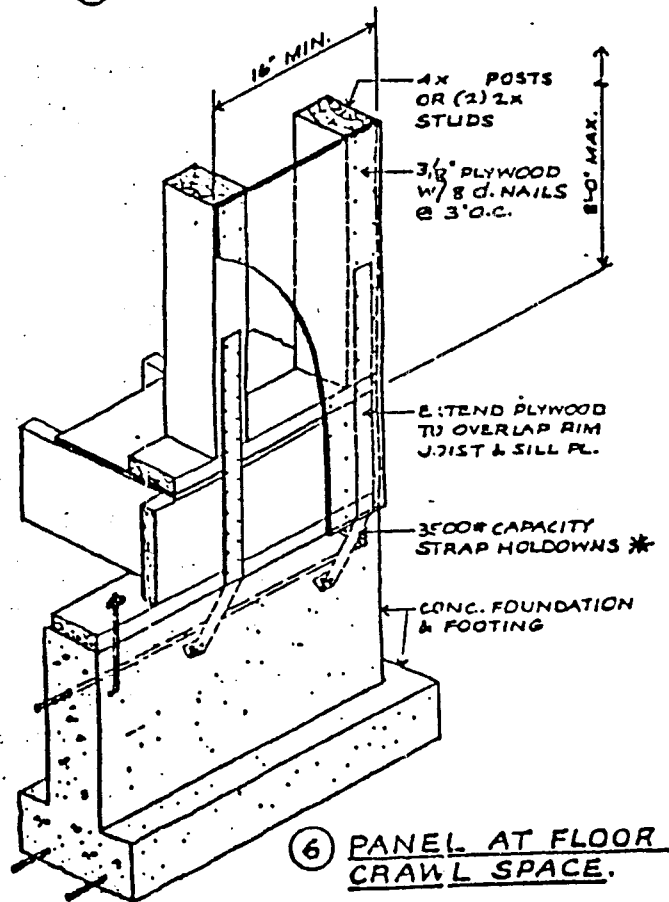

⑥ PANEL AT FLOOR
CRAWL SPACE.

LEWIS COUNTY DEPARTMENT OF BUILDING AND PLANNING

PRESCRIPTIVE WALL BRACING BASICS

PRESCRIPTIVE BUILDINGS

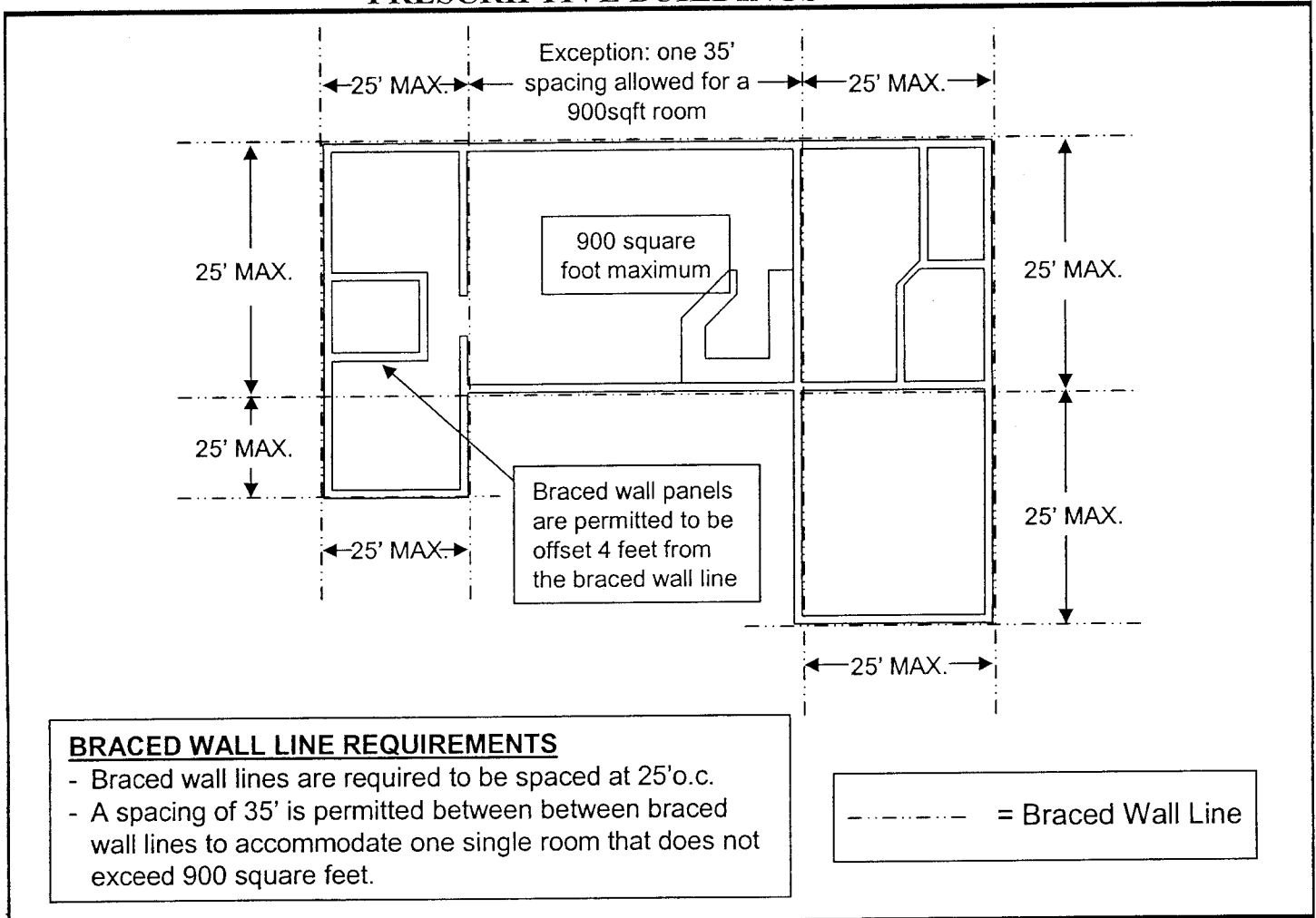

NON-PRESCRIPTIVE BUILDINGS

Buildings shall have a lateral-force-resisting system, that resists all wind and seismic loads, designed by a Washington State engineer or architect when any of the following occur:

1. When braced wall lines cannot meet the minimum requirements for the amount and locations of bracing required within the braced wall line.
2. When braced wall lines are not in plane vertically from the foundation to the uppermost story.
3. When a section of floor or roof, that extends more than six feet beyond a braced wall line, is not supported by shear walls or braced wall lines on all edges.
4. When braced wall panels are placed over openings in the wall below that exceed eight feet in width.
5. When an opening in the floor exceeds 12 feet in any dimension or exceeds 50% of the least floor dimension.
6. When braced wall lines do not occur in two perpendicular directions.

TABLE R602.10.6
MINIMUM WIDTHS AND TIE-DOWN FORCES OF ALTERNATE BRACED WALL PANELS

SEISMIC DESIGN CATEGORY AND WINDSPEED	TIE-DOWN FORCE (lb)	HEIGHT OF BRACED WALL PANEL				
		Sheathed Width				
		8 ft. 2' - 4"	9 ft. 2' - 8"	10 ft. 2' - 8"	11 ft. 3' - 2"	12 ft. 3' - 6"
SDC A, B, and C Windspeed < 110 mph	R602.10.6.1, Item 1	1800	1800	1800	2000	2200
	R602.10.6.1, Item 2	3000	3000	3000	3300	3600
SDC D ₀ , D ₁ and D ₂ Windspeed < 110 mph	R602.10.6.1, Item 1	Sheathed Width				
		2' - 8"	2' - 8"	2' - 8"	Note a	Note a
	R602.10.6.1, Item 2	1800	1800	1800	—	—
	R602.10.6.1, Item 2	3000	3000	3000	—	—

For SI: 1 inch = 25.4 mm, 1 foot = 304.8 mm.
a. Not permitted because maximum height is 10 feet.

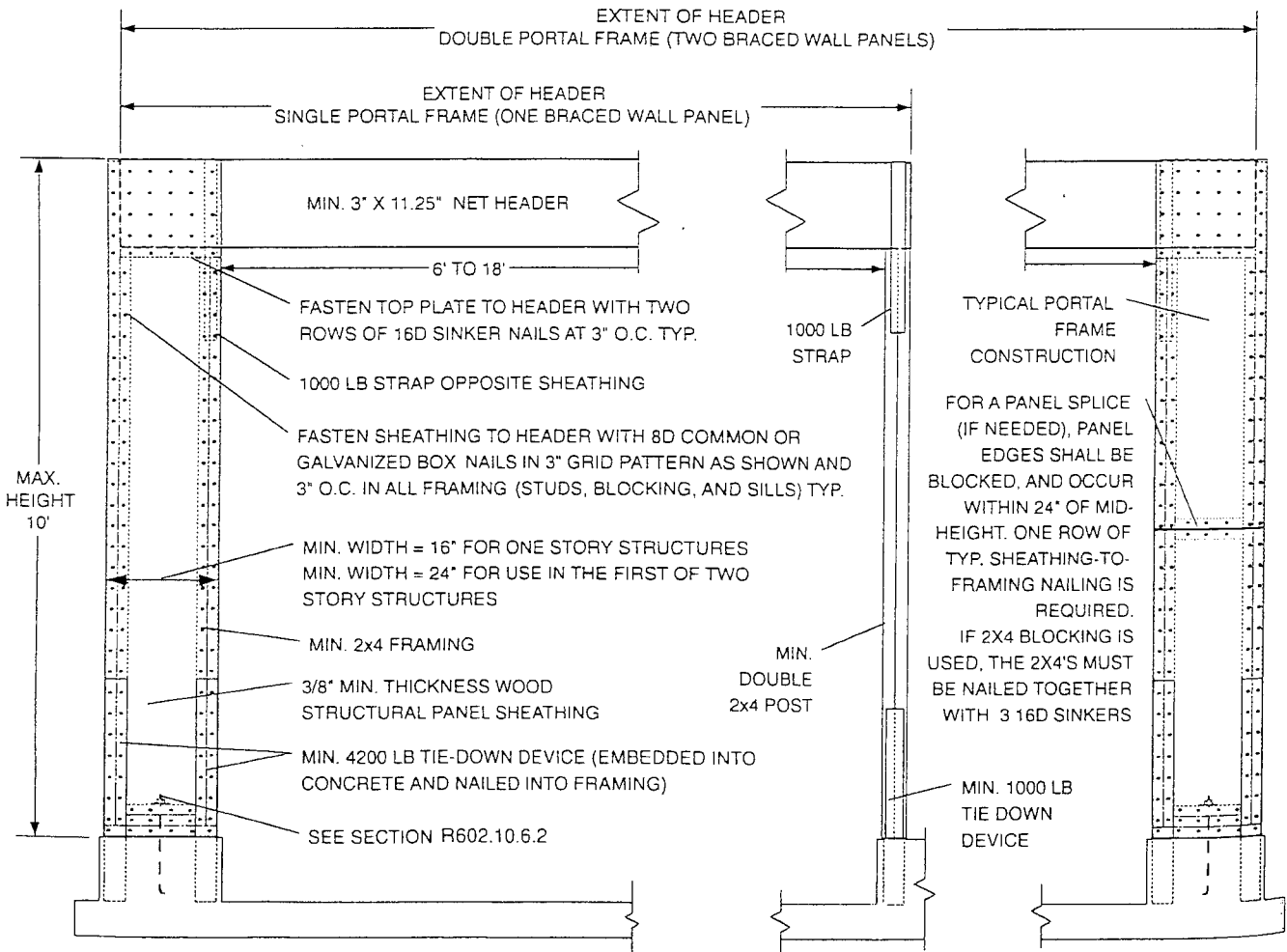

For SI: 1 inch = 25.4 mm, 1 foot = 304.8 mm, 1 pound = 0.454 kg.

FIGURE R602.10.6.2
ALTERNATE BRACED WALL PANEL ADJACENT TO A DOOR OR WINDOW OPENING

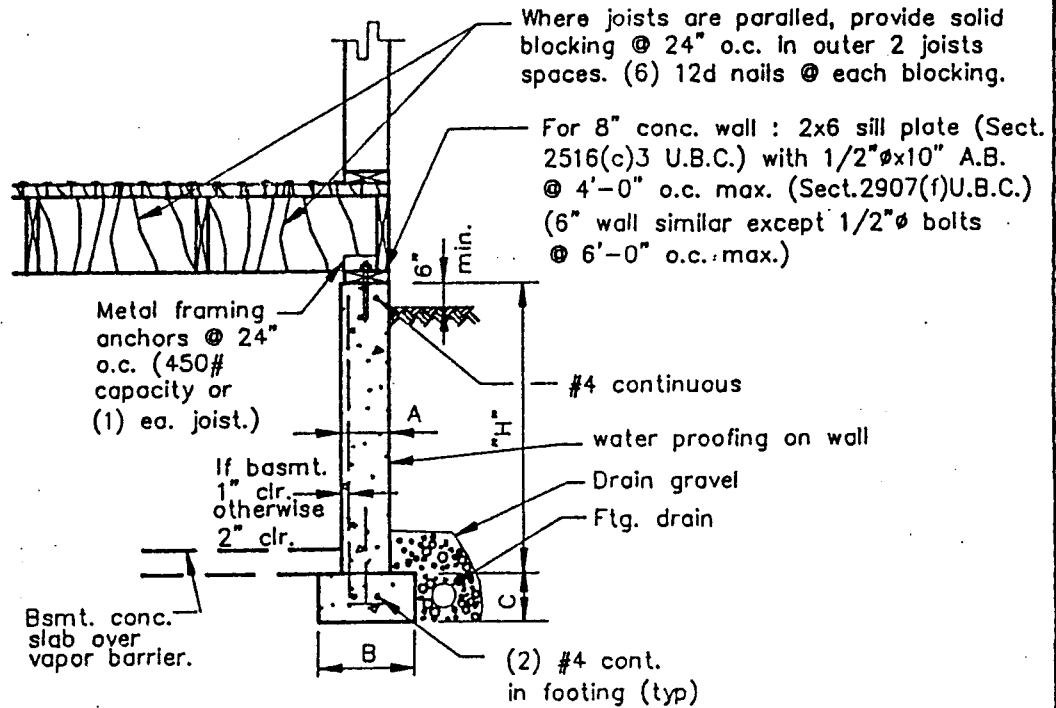

TYP. RESIDENTIAL FOUNDATION WALL

DO NOT BACKFILL UNTIL FLOOR DECKING IS NAILED

Height "H" in feet	Vertical Reinforcing	Horizontal Reinforcing
0 to 2' 6" min. wall	Not Required	(1) #4 Top bar
3' to 4' 6" min. wall	#4 @ 24" o.c.	#4 @ 24" o.c.
5' to 6' 8" min. wall	#4 @ 18" o.c.	#4 @ 18" o.c.
7' to 8' 8" min. wall	#4 @ 16" o.c.	#4 @ 18" o.c.

Concrete f'c = 2,000 psi minimum

All walls over 8'-0" high shall be designed by a Professional Engineer, Licensed by Washington State. (stamped drawings req'd.)

Lewis County Building Department

Lewis County Public Services Building
2025 NE Kresky Ave.
Chehalis, WA 98532 Phone: (360) 740-1146

SHEET NO.

S-2