

2022 ANNUAL BRIDGE REPORT



LEWIS COUNTY
PUBLIC WORKS

Submitted August 2022

[This page is intentionally left blank.]

Cover Photo Stowell Bridge #221

Credits

Joe Byers, Lead Inspector
Jay Noonan, Assistant Inspector

Tim Fife, P.E., County Engineer 9-19-22
Date

Geoff Soderquist, P.E., Assistant County Engineer 9/20/22
Date

Joe Byers, Senior Engineer Bridge-Non P.E. 9-19-22
Date

Jay Noonan, Assistant Inspector 9-19-22
Date



[This page is intentionally left blank.]



2022 Annual Bridge Report

Submitted: August 2022

This bridge report is prepared by Lewis County Public Works Engineering Services Bridge Department each year to fulfill requirements of the Washington Administrative Code (WAC) 136-20-060. This WAC requires the County Engineer's report of bridge inspections as follows:

Each county engineer shall furnish the county legislative authority with a written report of the findings of the bridge inspection effort. This report shall be made available to said authority and shall be consulted during the preparation of the proposed six-year transportation program revision. The report shall include the county engineer's recommendations as to replacement, repair or load restriction for each deficient bridge. The resolution of adoption of the six-year transportation program shall include assurances to the effect that the county engineer's report with respect to deficient bridges was available to said authority during the preparation of the program.



[This page is intentionally left blank.]

Table of Contents

Acronyms	9
Townsend Bridge Replacement	10
Cousins Road Culvert Replacement	12
Stowell Bridge Scour Repair	14
Highlights and Changes in 2022	15
Summary of Bridge Inventory	16
Scour Critical Bridges	17
Other Local Agency Bridges	17
Short Span Bridges	18
Bridge Inspection: Findings and Recommendations	19
Exhibit A – Lewis County Special Bridge Inspection	21
Bridge Load Ratings	22
Load Width and/or Height Restricted Bridges	23
Exhibit B – Lewis County Crossings – Width/Height/Weight Restrictions	24
2021 BRAC Approved Funding for Bridge Replacement and Rehabilitation	25
2022 BRAC Approved Funding for Bridge Replacement and Rehabilitation	26
2019 State/Federal Funded Fish Passage Projects	29
2020 FEMA Funded Culvert Replacement Project	30
2022 County Funded Bridge Repair Project	31
Lewis County Bridge Sufficiency Ratings – 2022	32
Exhibit C – Future Replacement/Rehabilitation Candidates	33
Maintenance and Repair Recommendations	34
Exhibit D – Work Orders Completed in 2020-2021	35
Glossary of Bridge Terms	37
Appendix A - Inventory	41
Lewis County 17 Short Span Bridges	43
Lewis County 84 Scour Critical Bridges	44
Lewis County 10 Culverts	47
Lewis County Bridge Inventory	48
Appendix B - Commissioner Districts	55
Appendix C - Emergency Bridge Inspection Priority Rating	57
Appendix D - Emergency Bridge Inspection and Liquefaction Susceptibility	59



[This page is intentionally left blank.]

Acronyms

The following is a list of common acronyms widely used in the bridge inspection field:

ADT	Average Daily Traffic
BRAC	Bridge Replacement Advisory Committee
CFR	Code of Federal Regulations
FEMA	Federal Emergency Management Agency
FHWA	Federal Highway Administration
FO	Functionally Obsolete
HBRRP	Highway Bridge Replacement and Rehabilitation Program
NBI	National Bridge Inventory
NBIS	National Bridge Inspection Standards
NSTM	Nonredundant Steel Tension Member
SC	Scour Critical
SD	Structurally Deficient
SID	Structure Identification Number
SR	Sufficiency Rating
UBIT	Under Bridge Inspection Truck
WAC	Washington Administrative Code
WSDOT	Washington State Department of Transportation



Townsend Bridge Replacement



TOWNSEND MP 0.22, Bridge # 223 Pre-Construction



TOWNSEND MP 0.22, Bridge # 223 Mid-Construction



TOWNSEND MP 0.22, Bridge # 223 Post-Construction

Cousins Road Culvert Replacement



COUSINS MP 3.15, Bridge # 79 Pre-Construction



COUSINS MP 3.15, Bridge # 79 Mid-Construction



COUSINS MP 3.15, Bridge # 79 Post-Construction

Stowell Bridge Scour Repair



STOWELL MP 0.57, Bridge # 221 Pre-Construction



STOWELL MP 0.57, Bridge # 221 Mid-Construction

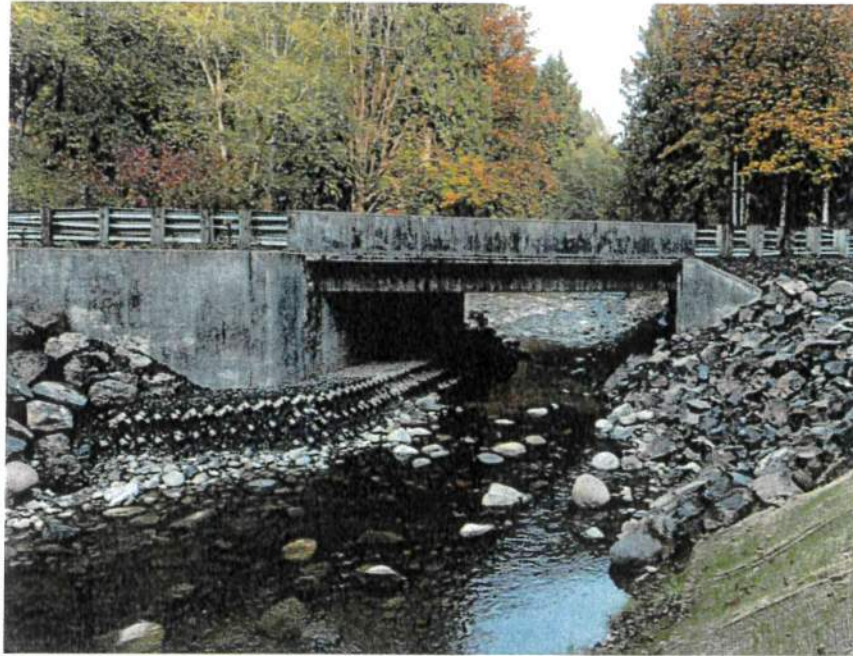

STOWELL MP 0.57, Bridge # 221 Post-Construction

Highlights and Changes in 2022

Lewis County replaced one bridge, Townsend MP 0.22 #223, and one newly constructed bridge was added to the County's inventory this last year, Cousins MP 3.15 #79. The County's now has 204 NBI reportable bridges.

Per CFR 650.311, all bridges are to be inspected every 24 months. Lewis County team members completed 108 routine and short span bridge inspections during the 2021-2022 cycle inspections, from September through March.

Lewis County also provided bridge inspection services for 6 locally owned bridges in the City of Winlock, the Town of Pe Ell, and the City of Napavine. Routine inspections are performed on these structures and soundings if needed.

Summary of Bridge Inventory

Lewis County's road system covers a vast 1,042 miles of roadway; and within that system are 204 NBI reportable bridges and 17 short span bridges that makeup the Lewis County Bridge Inventory. The County's inventory is comprised of 187 concrete structures, 13 steel structures, and 4 timber structures. Several of the concrete and steel structures also contain some timber components.

One of the County's bridges is classified as structurally deficient (SD), 24 are classified as functionally obsolete (FO), and 84 are coded as scour critical. A list of functionally obsolete and structurally deficient bridges is shown in Exhibit C (page #) and these bridges should be considered for future replacement or rehabilitation.

The Kernahan Bridge, #31157A, spans the Nisqually River and it connects Lewis County to Pierce County in the Ashford area. It is owned and inspected by Pierce County, but there is a shared maintenance agreement between the two counties. This bridge is not included in Lewis County's bridge inventory.

Lewis County has 1 pedestrian bridge, parallel to the Airport Road Bridge. This foot bridge is a steel structure and it is inspected biennially. Since there is no vehicular traffic and the bridge is only open to pedestrians and bicyclists, it is not included in the bridge inventory.

Bridge Inventory

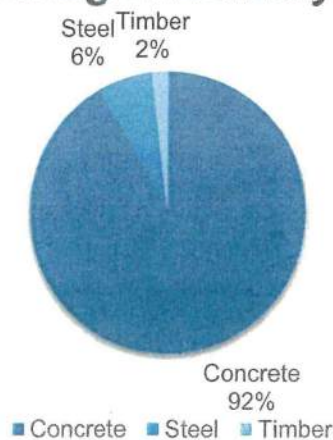

Scour Critical Bridges

In 1997, federally mandated scour evaluations were completed. Based on these evaluations and information taken from soundings performed, Lewis County has 84 scour critical bridges. Additional inspection is required at each scour critical bridge.

Structures are determined to be scour critical by the thalweg's location in relation to the footings (the thalweg is the deepest part of the stream channel) or if they have unknown foundation information (such as unknown footing elevations). Additionally, once a bridge is considered scour critical, it remains a scour critical bridge even if countermeasures have been installed.

There is a specific scour code used in NBIS to inform inspectors and reviewers of the scour nature of each bridge. A code 3 is scour critical and a code 7 is scour critical with the countermeasures installed. Of the Lewis County's 84 scour critical bridges, 27 are scour critical because of the thalweg location (code 3), 46 are scour critical because of unknown foundations (code 3), and 11 are scour critical with the countermeasures installed (code 7).

During the inspection of these bridges, soundings are taken and a streambed cross-section is made to continuously monitor the thalweg's location, depth, and migration throughout the channel. Scour critical bridges also receive additional inspections during or immediately after flood events as well.

Bridges acknowledged with unknown foundations are generally bridges built pre 1960. Plans for these bridges do not exist. When no plans are available, it is difficult to know what the foundation type is or what the depth of the foundation is compared to the thalweg. With the unknown foundation designation, these bridges are scour critical as well.

Other Local Agency Bridges

In addition to the Lewis County's bridge inventory, inspection services were provided to other political subdivisions upon request. The County currently works with two cities, one town, and one county under inter-local agreements and conditions set forth in the Revised Code of Washington (RCW) Chapter 39.34. The County's services are provided primarily to other agencies that lack resources and expertise to inspect their own bridge inventory. In the 2021-2022 inspection cycle the County inspected 1 bridge for the City of Napavine. The City of Winlock, Town of Pe Ell and Wahkiakum County's next routine inspections fall into the 2022-2023 inspection cycle.

Agency Bridges Served	
# Of Bridges	Agency
1	City of Napavine
2	Town of Pe Ell
3	City of Winlock
21	Wahkiakum County



Short Span Bridges

The Highway Bridge Replacement and Rehabilitation Program (HBRRP) excludes short span bridges, of 20 feet or less, from receiving federal funding. There are 17 short span bridges in the bridge inventory (see Appendix A).

Even though these structures are non-NBI reportable they are included in Lewis County's bridge files, inspected with routine inspections, and observed for scour critical findings for safety of the traveling public.



KATULA MP 0.05, Bridge # 140 built in 1952



Bridge Inspection: Findings and Recommendations

Bridge inspections are performed in accordance with the National Bridge Inspection Standards (NBIS) and in conformance with 23 CFR 650.3. These standards mandate that all public agencies with bridge inventory, inspect and report the findings at a minimum of once every 24 months (routine inspection). The inspector uses these standards (routine, non-redundant steel tension member, or underwater) to document the current condition of each bridge element listed. The deficiencies are coded to NBIS standards and show the degree of deterioration in various elements. The three primary elements are: deck, superstructure, and substructure. Special inspections are required for: bridges that have non-redundant steel tension members; bridges that have footings under water which cannot be seen or measured during low water times of the year (underwater inspection); or bridges that require equipment to get close visual access to bridge members (special equipment inspection).

Typically, steel truss bridges have non-redundant steel tension members. These are made of several steel members that are in tension loading. If one of the tension members fails, the bridge will suffer a complete failure. Bridges with non-redundant steel tension members are also inspected on a 24 month frequency.

Under Water Inspections are required every five years on bridges with piers that extend below low-water levels. Lewis County currently has Galvin Bridge footings inspected by the Washington State Department of Transportation (WSDOT) dive team for its underwater inspection. A list of special inspections with details on inspection frequencies can be found in Exhibit A.



Galvin Bridge #75, built in 1969 is a bridge that requires an underwater inspection every five years.

Every year the results of our inspection program are forwarded to WSDOT for review. Once the report has been accepted by WSDOT, it is available for the Federal Highway Administration (FHWA). A signed copy of each bridge inspection report is kept on file Lewis County.

The NBIS also has other factors which contribute to developing the overall rating of a bridge. Sufficiency Rating (SR) is a calculated score based on numbers assigned to all inspection factors reviewed by the inspector. The SR is a number from 0 to 100, with 100 being an entirely sufficient bridge, and 0 being an entirely insufficient or deficient bridge. Items that go into the determination of the SR include: load bearing capacity; average daily traffic; length of detour; geometry of the bridge; and the risk of scour at bridge foundations within waterway crossings.

As deterioration progresses, the coding values drop and work orders for repairs are issued. In the case where the coding factors are extremely low, recommendations are made for replacement or rehabilitation. Bridges with identified deficiencies may be inspected or monitored at more frequent intervals.

As of March 31, 2022 Lewis County has 24 bridges that are functionally obsolete (FO) with an SR less than 96 (See Exhibit C for the list of



FO bridges). Only those bridges that have an SR 80 and below are eligible for federal rehabilitation funding.

Special inspection equipment is used to inspect Lewis County steel truss structures and steel girder bridges. Currently Lewis County has an agreement with the City Of Seattle to rent their Under Bridge Inspection Truck (UBIT) with an operator and driver. UBIT inspections enable the inspector to be within an arm's reach of bridge elements as required by NBI standard.

Lewis County inspection team used their under bridge inspection trailer this cycle to conduct an in-depth inspection on the Ceres Hill MP 0.79, Bridge #102. Without the availability of the County's inspection trailer, the City of Seattle would have had to be retained to complete this inspection. Lewis County maintenance crews also used the trailer multiple time during 2021-2022 high water events to clear trees and debris from under bridges that had washed down stream and got hung up on the bridge piers.



Ceres Hill MP 0.79, Bridge #102



Exhibit A – Lewis County Special Bridge Inspection

Bridge	Name	Special Inspection	Last	2019	2020	2021	2022	2023
1	Davison MP 0.01	NSTM	Mar-17			X		X
12	Skate Crk South MP 0.45	NSTM	Mar-12			X		X
36	Coughlin MP 0.05	NSTM	Mar-11			X		X
75	Galvin MP 1.55	Underwater	Aug-12	X				
93	Ferrier MP 3.49	NSTM	Sep-14		X		X	
99	Hendrickson MP 0.03	NSTM	Mar-11			X		X
102	Ceres Hill MP 0.79	Equipment Inspection	Apr-1				X	
113	Kollock MP 0.19	Equipment Inspection	Mar-23			X		
117	Thompson MP 0.55	NSTM	Sep-16		X		X	
125	Mays MP 0.05	NSTM	Sep-15		X		X	
190	Toledo Salmon Crk MP 3.33	Equipment Inspection	Mar-23			X		



Bridge Load Ratings

The FHWA has mandated that all bridges undergo a new load rating to include Special Haul Vehicles (SHV) and Emergency Vehicles (EV). The EV are required to be load rated if they are within one road-mile from access to and from the National Network of highways. Lewis County has 4 additional bridges evaluated for the SHV and EV this year by Tran Tech Engineering LLC., a consulting engineering firm.

These bridges are being evaluated to ensure Lewis County is in compliance with National Bridge Inspection Standard (NBIS) requirements to meet posting provisions to determine safe live-load capacity on all unrestricted loads. Special Haul and Emergency Vehicles as defined by AASHTO Manual for Bridge Evaluation (MBE) for load ratings and posted bridges have been added to the load rating requirements.

FHWA has established a time line to be met with compliance by all agencies. These timelines are as follows:
(Excerpt from Federal Highway Administration's Load Rating of Specialized Hauling Vehicles dated Nov. 15, 2013)

Group 1: Bridges with the shortest span not greater than 200 feet should be re-rated after their next NBIS inspection, but no later than December 31, 2017, that were last rated by:

- a) either Allowable Stress Rating (ASR) or Load Factor Rating (LFR) method and have an operating rating for the AASHTO Routine Commercial Vehicle either Type 3, Type 3S2, or Type 3-3 less than 33 tons (English), 47 tons (English), or 52 tons (English) respectively; or
- b) Load and Resistance Factor Rating (LRFR) method and have a legal load rating factor for the AASHTO Routine Commercial Vehicle, either Type 3, Type 3S2 or Type 3-3, less than 1.3.

Group 2: Rate those bridges not in Group 1 no later than December 31, 2022.

For either group, if a re-rating is warranted due to changes of structural condition, loadings, or configuration, or other requirements, the re-rating should include SHVs.

Lewis County has 28 bridges that fit in the group 1 category. Work load rating these structures began in 2014. 27 load ratings have been completed and 1 is currently being completed to finish the group 1 task. In addition to the group 1 load ratings, 5 additional ratings have been completed: 2 new structures, 1 structure that was rated for emergency vehicles and 2 structures from the next group to be rated. The approximate cost of the load ratings to date is \$270,000. It is estimated that the cost of the final group 1 bridge will be \$9,000.

There are 110 Group 2 bridges that remain to be load rated by 2022, 3 of these bridges are currently being load rated. This work may be completed by a consulting engineering firm through an on-call consultant contract. Based on the average cost of recent load ratings, the estimated cost-to-complete could be as high as \$770,000.

Load Width and/or Height Restricted Bridges

Each bridge is required to have a "Load Rating" calculation. The Load Rating establishes how much weight the bridge can safely carry for several standard configurations of vehicle axle loads. Bridges with weight restrictions are load posted.

Lewis County has eight bridges with load restrictions. As of June 30, 2022, Davison #1, Wildwood #5, Hinning #8, Teague #24, Lincoln Cr. #28, Shorey #69, Ceres Hill #102, Leonard #199, and Frase #200 are the load restricted bridges in Lewis County's inventory.

Bridges that have traffic portals of 15 feet or less in height are required to be posted with height restrictions. See Exhibit B, next page, for bridges with height, width and/or load restrictions.



Ferrier Bridge #93 is posted with height restrictions



Hendrickson Bridge #99 with width restrictions



Davison Bridge #1 is posted with weight restrictions

Exhibit B - Lewis County Crossings - Width/Height/Weight Restrictions

Bridge #	Roadway	Crossing	Width Restriction	Height Restriction	Weight Restriction
1	Davison MP 0.01	Tilton River	17		X
4	Elk Creek MP 2.84	Elk Creek	14		
5	Wildwood MP 0.05	Stillwater Creek			X
8	Hining MP 0.23	Olequa Creek			X
24	Teague MP 0.08	Lincoln Creek			X
28	Lincoln Creek MP 8.57	Lincoln Creek			X
36	Coughlin MP 0.05	S FK Newaukum River	16.8		
69	Shorey MP 0.48	Newaukum River			X
93	Ferrier MP 3.49	Olequa Creek	17.6	11'9"	
99	Hendrickson MP 0.03	Stillwater Creek	17.6		
102	Ceres Hill MP 0.79	Chehalis River	16.2		X
113	Kollock MP 0.19	Olequa Creek	14		
114	Rock Creek MP 0.03	Rock Creek	14		
124	Hope Creek MP 0.94	Hope Creek	14		
131	Burri MP 0.13	Lake Creek	14		
139	Elk Creek MP 2.96	Eight Creek	14		
148	Cook MP 0.07	Lake Creek	16		
163	Berry MP 1.91	Stearns Creek	16.2		
190	Toledo Salmon Crk MP 3.33	Salmon Creek	14		
199	Leonard MP 2.52	Lacamas Creek			X
200	Frase MP 0.22	Kearney Creek			X

2021 BRAC Approved Funding for Bridge Replacement and Rehabilitation

Bridge #	Name	Repair or Replacement	Sufficiency Rating
172	SARGENT MP 1.33	Scour Repair	87.75
147	KING MP 12.26	Scour Repair	82.97



King Bridge #147



Sargent Bridge #172



2022 BRAC Approved Funding for Bridge Replacement and Rehabilitation

Bridge #	Name	Repair or Replacement	Sufficiency Rating
1	Davison MP 0.01	Bridge Rehabilitation	7.16
3	Wildwood MP 10.14	Scour Repair	78.01
8	Hining MP 0.23	Girder Repair	80.12
75	Galvin MP 1.55	Deck Sealing and Overlay	81.74
77	Senn MP 0.89	Scour Repair	90.69
112	Galvin MP 1.23	Deck Sealing and Overlay	88.86



Davison MP 0.01 Bridge #1



Davison MP 0.01 Bridge #1



Wildwood MP 10.14 Bridge #3



Wildwood MP 10.14 Bridge #3



Hinning MP 0.23 Bridge #8



Hinning MP 0.23 Bridge #8



Galvin MP 1.55 Bridge #75



Galvin MP 1.55 Bridge #75



Senn MP 0.89 Bridge #77



Senn MP 0.89 Bridge #77



Galvin MP 1.23 Bridge #112



Galvin MP 1.23 Bridge #112

2019 State/Federal Funded Fish Passage Projects

Lewis County will be adding one culvert/bridge to our inventory in 2022 through the State Funded Fish Passage Project. The replacement of a 5' by 7' corrugated metal squash pipe culvert with a 22' by 9' concrete box culvert on Centralia Alpha Road at M.P. 15.79 spanning Middle Fork Newaukum River.



Centralia Alpha Road MP 15.79 outlet



Centralia Alpha Road MP 15.79 inlet



2020 FEMA Funded Culvert Replacement Project

Lewis County will be adding one culvert/bridge to our inventory in 2022 through the FEMA funded damage replacement. The Crumb Road M.P. 0.17 culvert was damaged beyond repair during the 2020 flood event. The replacement of a 11' by 7' metal pipe arch with a 29' by 12' concrete box culvert on Crumb Road at M.P. 0.17 spanning Highland Creek.



Crumb Road MP 0.17 outlet



Crumb Road MP 0.17 roadway above culvert



2022 County Funded Bridge Repair Project

Lewis County will be advertising for a repair project of the FERRIER MP 3.49 bridge. The FERRIER bridge was built in 1924 and is a steel trough truss main span with wooden approach spans and is located on Ferrier Road at mile post 3.49. Recently there has been damage to the upper members of both portals (end of the bridge) and an upper cross bracing at the middle of the bridge from an over height truck. This bridge is posted at both bridge ends for height restrictions.

Repairs for this project are fabrication of new steel upper member at both ends and in the middle. Once fabricated the bent steel connected to the bridge will be members and replaced one at a time then the connection points will be painted.



Ferrier Bridge #93 bent cross bracing



Ferrier Bridge #93 bent portal bracing

Lewis County Bridge Sufficiency Ratings – 2022

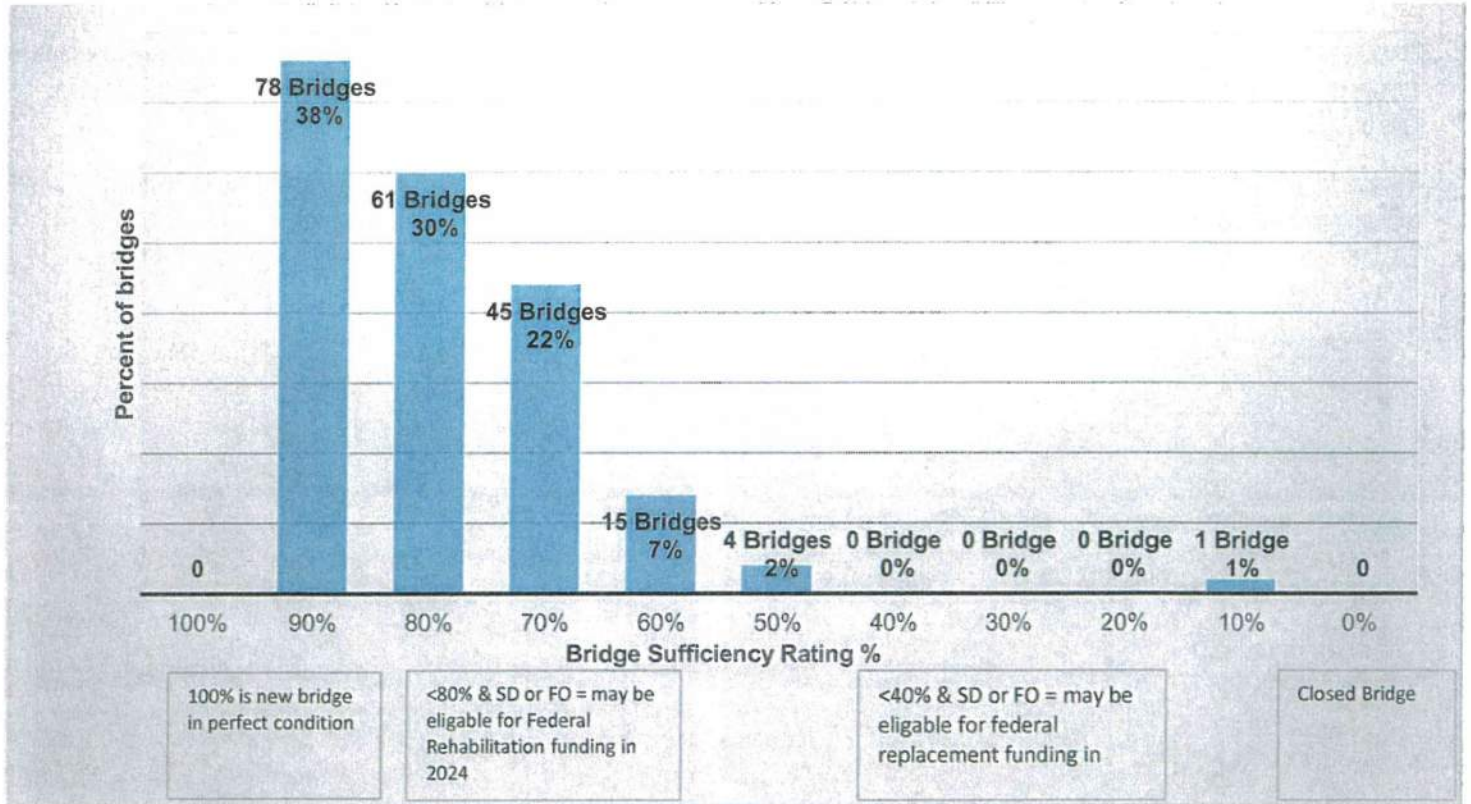

Exhibit C – Future Replacement/Rehabilitation Candidates

The following county bridges are listed, as of March 31, 2022, as functionally obsolete (FO) which is defined by FHWA as follows: a structure whose condition or design has impacted its ability to adequately carry its intended traffic loads. An FO bridge is one in which the deck geometry, load carrying capacity, clearance, or approach roadway alignment has reduced its ability to adequately meet the traffic needs. These bridges are below accepted design standards. Those bridges meeting the criteria for both SD and FO are only labeled SD, the structural deficiency overrides the functional obsolescence and the bridge will be considered in the SD classification.

At the top of the list for rehabilitation candidates is the Ceres Hill MP 0.79, Bridge #102. This bridge is a box girder single lane bridge built in 1948. A recent in-depth inspection revealed a series of structural defects that triggered a revised load rating to be completed. As a result of the new load rating the bridge was posted for below legal loading of multiple axle vehicles. Funding has been requested to assist in the cost of a repair to return the bridge back to its non-restrictive load carrying capacity.

Functionally Obsolete Bridges			
Bridge #	Name	Sufficiency Rating	SD/FO
1	Davison MP 0.01	7.16	SD
4	Elk Creek MP 2.84	70.69	FO
8	Hining MP 0.23	80.12	FO
13	Airport MP 1.42	74.71	FO
36	Beaver Creek MP 0.02	95.33	FO
41	Jylha MP 0.01	87.45	FO
45	Teitzel MP 0.79	85.72	FO
50	Coughlin MP 0.05	57.06	FO
69	Shorey MP 0.48	67.40	FO
80	Hyppa MP 0.01	82.76	FO
81	Kruger MP 0.69	67.88	FO
84	Pigeon Springs MP 1.95	82.62	FO
L93	Ferrier MP 3.49	71.64	FO
99	Hendrickson MP 0.03	65.84	FO
102	Ceres Hill MP 0.79	10.98	FO
124	Hope Creek MP 0.94	72.99	FO
128	Shorey MP 0.81	78.46	FO
139	Elk Creek MP 2.93	65.59	FO
148	Cook MP 0.07	78.35	FO
163	Berry MP 1.91	78.20	FO
166	Brown West MP 0.11	69.74	FO
174	Stover MP 0.03	75.29	FO
196	Mandy MP 2.02	74.57	FO
212	Meade Hill MP 0.61	67.40	FO
228	Hwy 603 MP 13.39	69.24	FO

Maintenance and Repair Recommendations

The majority of bridge repair and maintenance work is done by county crews, with support from various vendors. This work includes: cleaning minor painting, and replacing existing components which have deteriorated (see Exhibit D). Other routine maintenance may include minor fascia repairs in wing walls, retaining walls, asphalt approaches, concrete repair, and bridge cleaning.

Bridges with Scour Concerns			
Bridge #	Name & Mile Post	Year Built	Scour Code
3	Wildwood MP 10.14	1955	3
39	Independence MP 0.33	1956	5
42	Independence MP 3.42	1956	5
66	North Fork MP 0.35	1958	5
77	Senn MP 0.89	1966	3
78	Labree MP 1.18	1970	3
99	Hendrickson MP 0.03	1927	3
130	Curtis Hill MP 3.28	1960	3
147	King MP 12.26	1960	3
149	King MP 1.59	1958	U
172	Sargent MP 1.33	1972	3
209	Wilson MP 0.23	1957	U



Exhibit D – Work Orders Completed in 2020-2021

Name	Date Noted	Comments
Various Bridges	2021-2022	Brush removal for routine inspections
Various Bridges	2021-2022	Bridge cleaning
Various Bridges	2021-2022	Wooden debris removal under bridges



[This page is intentionally left blank.]



Glossary of Bridge Terms

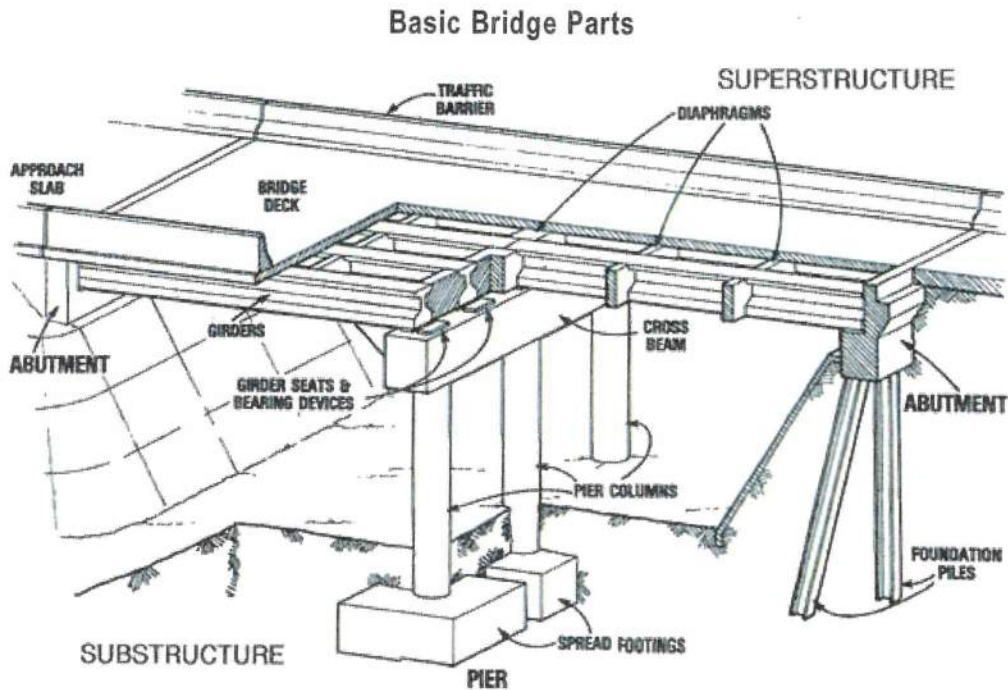

Abutment – a substructure supporting the end of a single span, or the extreme end of a multi-span super structure and, in general, retaining or supporting the bridge approach fill.

Approach Span – the span or spans connecting the abutment with the main span or spans.

Back Wall – the top-most portion of an abutment functioning primarily as a retaining wall to contain approach roadway fill.

Beam – a linear structural member designed to span from one support to another.

Bent – a supporting unit of the beams of a span made up of one or more column or column-like members connected at their top-most ends by a cap, strut, or other horizontal member.

Bracing – a system of tension or compression members, or a combination of these, connected to the parts to be supported or strengthened by a truss or frame. It transfers wind, dynamic,

impact, and vibratory stresses to the substructure and gives rigidity throughout the complete assemblage. Can also refer to diagonal members that tie two or more columns of a bent together.

Box Girder – a support beam that is a hollow box; its cross-section is a rectangle or square.

Cap – the horizontally-oriented, top-most piece or member of a bent serving to distribute the beam loads upon the columns and to hold the beams in their proper relative positions.

Cast-In-Place – concrete poured within form work on site to create a structural element in its final position.

Catwalks – temporary foot bridges, used by bridge inspection personnel.

Chord – in a truss, the upper-most and the lower-most longitudinal members, extending the full length of the truss.



Column – a vertical structural member that transfers dead and live load from the bridge deck and girders to the footings or shafts.

Column Cross Brace – transverse brace between two main longitudinal members.

Compression – a type of stress involving a pressing or squeezing together, tends to shorten a member, opposite of tension.

Culvert – a pipe or small structure used for drainage under a road, railroad or other embankment. A culvert with a span length greater than 20 feet is included in the National Bridge Inventory and receives a rating using the NBI scale.

Dead Load – a static load due to the weight of the structure itself.

Deck – the roadway portion of a bridge that provides direct support for vehicular and pedestrian traffic.

Deck Bridge – a bridge in which the supporting members are all beneath the roadway.

Deck Truss – a bridge whose roadway is supported from beneath by a truss.

Diagonal – a sloping structural member of a truss or bracing system.

Elastomeric Pads – rectangular pads made of neoprene, found between the sub-structure and superstructure that bears the entire weight of the superstructure. Elastomeric pads can deform to allow for thermal movements of the superstructure.

End Wall – the wall located directly under each end of a bridge that holds back approach roadway fills. The end wall is part of the abutment.

Expansion Joint – a joint designed to provide means for expansion and contraction movements produced by temperature changes, load, or other forces.

Fatigue – cause of structural deficiencies, usually due to repetitive loading over time.

Footing – the enlarged, lower portion of a sub-structure that distributes the structure load either to the earth or to supporting piles; the most common footing is the concrete slab; “footer” is a colloquial term for footing.

Fracture Critical Member – a member in tension or with a tension element whose failure would probably cause a portion of or the entire bridge to collapse.

Girder – a main support member for the structure that usually receives loads from floor beams and stringers; also, any large beam, especially if built up.

Hanger – a tension member serving to suspend an attached member.

Hinge – a point in structure at which a member is free to rotate.

Live Load – vehicular traffic, wind, water, and/or earthquakes.

Lower Chord – the bottom horizontal member of a truss.

Main Beam – a beam supporting the spans and bearing directly onto a column or wall.

Member – an individual angle, beam, plate, or built piece intended to become an integral part of an assembled frame or structure.

Oscillation – a periodic movement back and forth between two extreme limits. An example is the string of a guitar that has been plucked. Its vibration back and forth is one oscillation. A vibration is described by its size (amplitude), its oscillation rate (frequency), and its timing (phase). In a suspension bridge, oscillation results from energy collected and stored by the bridge. If a part of the bridge has to store more energy than it is capable of storing, that part will fail.

Pier – a structure comprised of stone, concrete, brick, steel, or wood that supports the ends of the spans of a multi-span superstructure at an intermediate location between abutments. A pier is usually a solid structure as opposed to a bent, which is made up of columns.

Pile – a linear (vertical) member of timber, steel, concrete, or composite materials driven into the earth to carry structure



loads into the soil.

Pile Bent – a row of driven or placed piles with a pile cap to hold them in their correct positions; see “Bent.”

Plate Girder – a large, solid web plate with flange plates attached to the web plate by flange angles or fillet welds. Typically fabricated from steel.

Post or Column – a member resisting compressive stresses, in a vertical or near vertical position.

Pre-Cast Girder – fabricated off site of Portland Cement Concrete, reinforcing steel and post-tensioning cables. These girders are shipped to the construction site by truck and hoisted into place by cranes.

Reinforced Concrete – concrete with steel reinforcing bars bonded within it to supply increased tensile strength and durability.

Scour – erosive action of removing streambed material around bridge substructure due to water flow. Scour is of particular concern during high-water events.

Short Span Bridge – these bridges have a single NBIS span length of 20 feet or less. They are typically supported by timber piles or shallow concrete footings.

Soffit – the underside of the bridge deck or sidewalk.

Spall – a concrete deficiency wherein a portion of the concrete surface is popped off from the main structure due to the expansive forces of corroding steel rebar underneath. This is especially common on older concrete bridges.

Span – the distance between piers, towers, or abutments.

Steel – a very hard and strong alloy of iron and carbon

Stringer – a longitudinal beam (less than 30 feet long) supporting the bridge deck, and in large bridges, framed into or upon the floor beams.

Sufficiency Rating – the sufficiency rating is a numeric value from 100 (a bridge in new condition) to 0 (a bridge incapable of carrying traffic). The sufficiency rating is the summation of four

calculated values: Structural Adequacy and Safety, Serviceability and Functional Obsolescence, Essentiality for Public Use, and Special Reductions.

Substructure – the abutment, piers, grillage, or other structure built to support the span or spans of a bridge superstructure, and distributes all bridge loads to the ground surface. Includes abutments, piers, bents, and bearings.

Superstructure – the entire portion of a bridge structure which primarily receives and supports traffic loads and in turn transfers the reactions to the bridge substructure; usually consists of the deck and beams or, in the case of a truss bridge, the entire truss.

Tension – type of stress involving an action which pulls apart.

Tie – a member carrying tension.

Torsion – a twisting force or action.

Trestle – a bridge structure consisting of beam spans supported upon bents. Trestles are usually made of timber and have numerous diagonal braces, both within each bent and from bent to bent.

Truss – a rigid, jointed structure made up of individual straight pieces arranged and connected, usually in a triangular pattern, so as to support longer spans.

Truss Bridge – a bridge having a pair of trusses for the superstructure.

Upper Chord – the top longitudinal member truss.

Web – the portion of a beam located between and connected to the flanges.

Welded Joint – a joint in which the assembled elements and members are united through fusion of metal.

Wheel Rail – a timber curb fastened directly to the deck, most commonly found on all-timber bridges.

Wing Wall – walls that slant outward from the corners of the overall bridge that support roadway fill of the approach.



[This page is intentionally left blank.]



APPENDIX A



[This page is intentionally left blank.]

Lewis County | 17 Short Span Bridges

Bridge	Name	Length-Ft	Width-Ft	Traffic	Year Built	Detour Length
26	Teague MP 0.57	21	20	105	1956	*
43	Big Hanaford MP 0.67	22	32	693	1985	9
57	Salzer Valley MP 3.27	21	28	443	1984	6
85	Jorgensen MP 1.82	20	24	662	1961	9
86	Little Hanaford MP 5.08	22	28.8	184	1997	*
121	Ingalls MP 0.22	16	20	212	1956	35
133	Jackson Hwy MP 1.96	22	36	5609	1926	6
134	Logan Hill MP 0.10	11	24	1108	1954	2
140	Katula MP 0.05	18	20	49	1952	*
151	Conrad MP 1.98	15	20	18	1957	4
157	Coal Creek MP 1.72	22	29.7	1010	1976	12
175	Silverbrook MP 5.34	21	23.2	96	1969	6
182	Peters Creek MP 0.19	18	24	4	1964	*
202	Van Hoesen MP 0.43	22	20	47	1957	*
208	Isbell MP 0.17	14	20	275	1958	3
217	Peters MP 0.62	20	24.2	244	1964	8
227	Jeffries MP 0.85	22	22.5	101	1962	2

*= detour route not available or greater than 99 miles

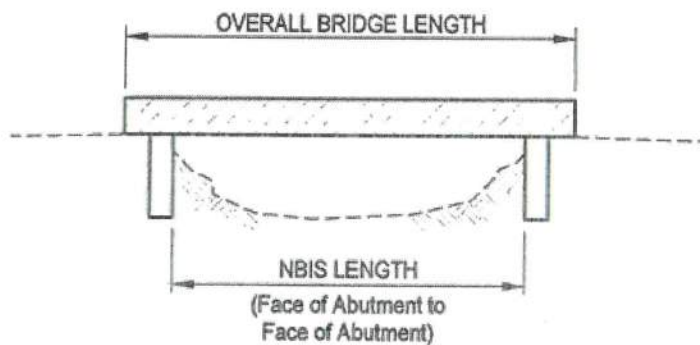

Short Span Bridges:

Bridges with an NBIS length of 20 feet or less are classified as short span bridges and are not eligible for BRAC funding under the current federal funding policy. There are currently no short span bridges recommended for replacement or rehabilitation.



Lewis County | 84 Scour Critical Bridges

Bridge #	Bridge Name	Length-Ft	Curb to Curb	Traffic	Year Built	Detour	Scour
3	WILDWOOD MP 10.14	124	22.2	284	1955	36	3
6	LOST VALLEY MP 0.29	180	28.3	175	1995	10	3
12	SKATE CREEK MP 0.53	392	26	1331	1953	79	7
13	AIRPORT MP 1.42	61	25	7230	1952	2	U
17	KIRKLAND MP 0.31	223	28	674	1973	2	7
27	TAUSCHER MP 1.99	49	24	202	1951	4	U
30	INGALLS MP 2.11	50	21.5	248	1953	35	U
37	GARRARD CREEK MP 4.35	59	24	107	1965	22	U
38	GARRARD CREEK MP 5.09	43	28	175	1972	22	U
40	NELSON MP 0.16	63	20	87	1955	*	U
44	CENTRALIA ALPHA MP 10.03	140	24.1	839	1960	3	3
49	BIG HANAFORD MP 6.68	30	20	189	1955	16	U
53	LITTLE HANAFORD MP 5.35	31	20.2	134	1957	2	U
58	MIDDLE FORK MP 0.41	158	24	1424	1956	3	3
61	DREWS PRAIRIE MP 1.21	101	28	309	1971	1	U
63	PE ELL MCDONALD MP 8.68	180	24.4	320	1959	12	7
64	REYNOLDS AVE MP 0.52	24	33	10213	1955	10	U
65	BISHOP MP 1.54	22	0	3654	1955	5	U
69	SHOREY MP 0.48	380	24	2826	1960	6	U
75	GALVIN MP 1.55	400	28	1941	1969	10	3
77	SENN MP 0.89	60	24	45	1966	2	3
78	LABREE MP 1.18	180	28	750	1970	3	3
81	KRUGER MP 0.69	25	18.2	248	1950	*	U
89	BOISTFORT MP 4.59	440	28	829	1982	29	7
94	NORTH FORK MP 7.19	175	25	212	1963	*	U
95	NORTH FORK MP 4.83	145	28	441	1980	3	7
99	HENDRICKSON MP 0.03	157	17.6	78	1927	*	3
102	CERES HILL MP 0.79	200	16.2	144	1948	13	7
103	DEEP CREEK MP 3.18	53	30	163	1978	*	3
104	TOOLEY MP 0.84	118	28	103	1977	5	3
105	JACKSON HWY SO. MP 1.01	217	34.2	1368	1923	5	3
106	DEEP CREEK MP 3.44	50	30	163	1978	*	3
107	CANNON MP 2.01	110	28	757	1976	*	7
112	GALVIN MP 1.23	382	28	1941	1993	10	3
114	ROCK CREEK MP 0.03	76	14	17	1985	*	3
120	STEARNS HILL MP 0.08	45	28	9	1984	*	3
122	BUNKER MP 0.26	30	20	51	1955	*	U



123	BUNKER MP 0.71	30	20	51	1955	*	U
128	SHOREY MP 0.81	30	24.3	2814	1955	7	7
129	CERES HILL MP 7.18	113	24	159	1963	7	3
130	CURTIS HILL MP 3.28	46	24	552	1960	9	3
131	BURRI MP 0.13	60	14	47	1988	*	3
135	JACKSON HWY MP 4.56	82	36	3427	1926	8	U
136	JACKSON HWY MP 4.62	82	36	3427	1926	8	U
137	JACKSON HWY MP 4.67	55	36	3427	1926	8	U
143	PE ELL MCDONALD MP 6.35	30	21.2	212	1958	12	U
144	PE ELL MCDONALD MP 7.31	30	23.8	259	1956	12	U
145	ROUNDTREE MP 0.29	28	20.4	41	1960	*	U
146	LOST VALLEY MP 0.83	30	20	124	1953	9	U
147	KING MP 12.26	46	26	148	1960	2	3
149	KING MP 1.59	31	20.8	235	1958	9	U
150	COMA MP 1.89	46	24	66	1960	3	U
152	TELEGRAPH MP 0.77	23	24	102	1954	8	U
153	TELEGRAPH MP 0.55	30	24	122	1965	8	U
154	MINKLER MP 0.04	26	24	606	1951	6	U
156	ANTRIM MP 0.57	30	20	324	1958	3	U
159	TAYLOR MP 0.45	30	20.2	80	1954	*	U
164	PLEASANT VALLEY MP 5.45	80	32	474	1975	2	3
165	BROWN WEST MP 0.34	28	25	235	1950	1	U
166	BROWN WEST MP 0.11	28	18.1	235	1950	1	U
167	HAYWIRE MP 2.80	24	24	168	1963	5	U
172	SARGENT MP 1.33	74	28	581	1972	5	3
183	STOWELL MP 1.42	32	24	332	1960	6	U
185	BAKER MP 0.58	112	20	23	1936	1	3
186	BAKER MP 0.70	72	20	18	1936	*	3
187	JACKSON HWY MP 12.36	27	36	985	1926	8	U
188	SCHMIT MP 1.73	65	20.5	22	1953	*	3
189	JACKSON HWY MP 12.40	27	36	985	1926	8	U
190	TOLEDO SALMON CK MP 3.33	87	14	31	1977	*	7
191	JACKSON HWY MP 12.12	27	36	936	1926	8	U
193	SKATE CREEK S. MP 0.45	92	26.6	1359	1955	75	U
194	WALKER MP 0.68	24	20	76	1957	3	U
196	MANDY MP 2.02	78	20	142	1953	4	U
199	LEONARD MP 2.52	32	26	1725	1962	4	U
200	FRASE MP 0.22	53	19.2	4	1967	*	3
201	OYLER MP 3.24	30	24	398	1952	7	7
207	MINERAL CREEK MP 0.44	52	24	364	1967	*	3
209	WILSON MP 0.23	24	20	124	1957	*	U



210	SALMON CREEK MP 0.19	60	20	192	1953	*	U
211	ANDERSON MP 0.56	60	24.2	83	1965	5	3
212	MEADE HILL MP 0.61	36	20.5	245	1958	4	U
214	CISPUS MP 3.01	31	24.2	204	1952	5	U
221	STOWELL MP 0.57	30	30.8	325	1955	4	7
224	KIONA MP 0.35	50	24.2	724	1962	8	U



Lewis County | 10 Culverts

Bridge	Name	Length-	Lanes	Traffic	Year	Detour
21	Howe MP 2.60	31	2	40	2003	5
65	Bishop MP 1.54	22	2	3654	1955	5
67	Toledo Salmon CK MP 2.74	28	2	104	1955	*
71	Lucas Creek MP 5.17	21	2	9	2006	*
73	Pattee MP 0.82	21	2	52	2007	*
74	Logan Hill MP 1.10	28	2	1001	2007	4
76	Anderson MP 0.05	26	2	36	2009	*
110	Carr MP 2.74	24	2	10	2009	*
160	Henriot MP 0.48	32	2	349	1975	5
192	Jackson Hwy MP 14.00	48	2	932	1926	8

*=detour not available or greater than 99 miles

- A = Structure length
- B = NBIS Length (WB73 - 46)
- C = Maximum span length
- D = the distance between consecutive pipes, which must be = or < the diameter of the smallest pipe in the series.

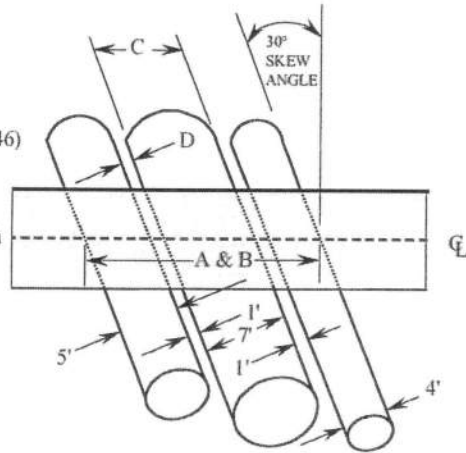

$$\text{Opening Distance} = 18' = 5' + 1' + 7' + 1' + 4'$$

$$A \text{ (normal to the pipes)} = \frac{18'}{\cos(30)} = \frac{18'}{.867} = 20.76' \text{ (Code: 20')}$$

$$C = \frac{7}{\cos(30)} = 8.08' \text{ (Code: 8')}$$



Lewis County Bridge Inventory

Bridge	Bridge Name	Length-Ft	Curb to Curb	Traffic	Year Built	Detour Length
1	Davison MP 0.01	103	17	117	1924	*
2	Holcomb MP 0.81	25	29.3	163	1940	6
3	Wildwood MP 10.14	124	22.2	284	1955	36
4	Elk Creek MP 2.84	54	14	192	1952	*
5	Wildwood MP 0.05	150	24.3	239	1962	36
6	Lost Valley MP 0.29	180	28.3	175	1995	10
7	Newaukum Valley MP 2.38	24	24.4	162	1950	7
8	Hining MP 0.23	76	23.7	29	1957	1
9	Maschke MP 0.03	120	26	37	1974	*
10	Wildwood MP 5.19	204	22.4	191	1955	36
11	Twin Oaks MP 1.37	34	24	671	1950	7
12	Skate Creek MP 0.53	392	26	1331	1953	79
13	Airport MP 1.42	61	25	7230	1952	2
14	Big Hanaford MP 9.50	70	29.6	36	2003	*
15	Wildwood MP 4.81	130	28.4	174	1970	36
16	Brim Creek MP 0.23	95	24	95	1960	6
17	Kirkland MP 0.31	223	28	674	1973	2
18	Chandler MP 1.37	158	24	69	1962	3
19	Goodrich MP 0.50	154	24	323	1961	*
20	Jackson Hwy MP 4.49	179	40	3565	2011	8
21	Howe MP 2.60	31	0	40	2003	5
22	Lincoln Creek MP 1.02	144	29.7	710	1976	35
23	Hadaller MP 0.42	112	26	438	1961	*
24	Teague MP 0.08	68	24	43	1964	*
25	Boistfort MP 1.09	204	24.3	657	1958	7
27	Tauscher MP 1.99	49	24	202	1951	4
28	Lincoln Creek MP 8.57	87	30	266	1977	35
29	Lincoln Creek MP 9.83	120	28	269	1997	35
30	Ingalls MP 2.11	50	21.5	248	1953	35
31	Lincoln Creek MP 11.91	60	29.7	218	2016	*
32	Harrison Ave MP 2.54	69	40	10844	1926	11
33	Falls MP 3.12	102	30.5	115	2004	*
34	Garrard Creek MP 0.07	73	24	219	1968	22
35	Garrard Creek MP 0.22	40	24	192	1965	22
36	Coughlin MP 0.05	100	16.8	27	1922	*
37	Garrard Creek MP 4.35	59	24	107	1965	22
38	Garrard Creek MP 5.09	43	28	175	1972	22



Bridge	Bridge Name	Length-Ft	Curb to Curb	Traffic	Year Built	Detour Length
39	Independence MP 0.33	104	24	416	1956	18
40	Nelson MP 0.16	63	20	87	1955	*
41	Jylha MP 0.01	74	28	56	1971	*
42	Independence MP 3.42	82	26	523	1956	18
44	Centralia Alpha MP 10.03	140	24.1	839	1960	3
45	Beaver Creek MP 0.02	134	28	109	1982	2
46	Pleasant Vly Est MP 0.29	67	28	189	1976	*
47	Big Hanaford MP 1.13	70	32	798	1974	10
48	Big Hanaford MP 2.11	51	32	561	1974	10
49	Big Hanaford MP 6.68	30	20	189	1955	16
50	Teitzel MP 0.79	46	24	78	1966	8
51	Deep Creek MP 3.93	78	28	10	2007	*
52	Elk Creek MP 0.85	162	20.4	355	1951	6
53	Little Hanaford MP 5.35	31	20.2	134	1957	2
54	Annonen MP 0.14	140	28	92	2002	2
55	Chandler MP 0.06	240	28	500	2010	6
56	Elk Creek MP 0.18	220	24.3	415	1963	6
58	Middle Fork MP 0.41	158	24	1424	1956	3
59	Haywire MP 2.40	22	25	238	1940	5
60	Haywire MP 2.55	23	20	163	1940	2
61	Drews Prairie MP 1.21	101	28	309	1971	1
62	Proffit MP 0.05	36	24	169	1960	6
63	Pe Ell Mcdonald MP 8.68	180	24.4	320	1959	12
64	Reynolds Ave MP 0.52	24	33	10213	1955	10
65	Bishop MP 1.54	22	0	3654	1955	5
66	North Fork MP 0.35	204	24	1493	1958	3
67	Toledo Salmon Ck MP 2.74	28	0	104	1955	*
68	Centralia Alpha MP 0.17	69	28	1510	1983	12
69	Shorey MP 0.48	380	24	2826	1960	6
70	Leonard MP 0.32	150	28	2056	1992	9
71	Lucas Creek MP 5.17	21	0	9	2006	*
72	Alvord MP 0.32	47	24	33	1964	*
73	Pattee MP 0.82	21	30	52	2007	*
74	Logan Hill MP 1.10	28	30.5	1001	2007	4
75	Galvin MP 1.55	400	28	1941	1969	10
76	Anderson MP 0.05	26	30	36	2009	*
77	Senn MP 0.89	60	24	45	1966	2
78	Labree MP 1.18	180	28	750	1970	3
79	Cousins MP 3.15	45	28	168	2021	*
80	Hyppa MP 0.01	73	24	23	1968	*



Bridge	Bridge Name	Length-Ft	Curb to Curb	Traffic	Year Built	Detour Length
81	Kruger MP 0.69	25	18.2	248	1950	*
82	Blanchard MP 0.87	32	28	143	1955	2
83	Wildwood MP 2.99	30	25	170	2013	39
84	Pigeon Springs MP 1.95	32	18.3	35	1954	*
88	Pleasant Vly Est MP 3.45	26	27.9	13	2017	*
89	Boistfort MP 4.59	440	28	829	1982	29
90	North Fork MP 0.70	300	34	1259	2000	6
91	North Fork MP 6.11	161	24	274	1962	*
92	Chilvers MP 1.55	28	30	891	1980	4
93	Ferrier MP 3.49	153	17.6	217	1924	5
94	North Fork MP 7.19	175	25	212	1963	*
95	North Fork MP 4.83	145	28	441	1980	3
96	Jorgensen MP 0.45	170	27.9	798	1996	9
97	Gish MP 0.03	170	28.2	513	1996	8
98	Guerrier MP 0.01	170	28.2	154	1996	*
99	Hendrickson MP 0.03	157	17.6	78	1927	*
100	Winlock Vader MP 0.26	116	24.3	1887	1928	2
101	Tauscher MP 2.64	123	28	114	1991	4
102	Ceres Hill MP 0.79	200	16.2	144	1948	13
103	Deep Creek MP 3.18	53	30	163	1978	*
104	Tooley MP 0.84	118	28	103	1977	5
105	Jackson Hwy So. MP 1.01	217	34.2	1368	1923	5
106	Deep Creek MP 3.44	50	30	163	1978	*
107	Cannon MP 2.01	110	28	757	1976	*
108	Jones MP 0.06	130	24	13	2004	*
109	Mineral Creek MP 1.21	200	28	168	2005	*
110	Carr MP 2.74	24	38.6	10	2009	*
111	Silverbrook MP 2.61	130	34	368	2006	1
112	Galvin MP 1.23	382	28	1941	1993	10
113	Kollock MP 0.19	95	14	45	1977	*
114	Rock Creek MP 0.03	76	14	17	1985	*
115	Osborn MP 0.27	61	24	301	1968	*
116	Craig MP 0.48	100	28	75	1978	5
117	Thompson Road MP 0.55	162	21.7	39	1936	1
118	Bunker Creek MP 3.46	72	28	538	1983	35
119	Bunker Creek MP 3.50	111	28	1138	1983	35
120	Stearns Hill MP 0.08	45	28	9	1984	*
122	Bunker MP 0.26	30	20	51	1955	*
123	Bunker MP 0.71	30	20	51	1955	*
124	Hope Creek MP 0.94	40	14	1	2000	*



Bridge	Bridge Name	Length-Ft	Curb to Curb	Traffic	Year Built	Detour Length
125	Mays Bridge MP 0.05	209	28	316	2015	7
126	Twin Oaks MP 0.32	107	30	743	1979	7
127	Bunker Creek MP 5.95	29	26.5	571	2018	35
128	Shorey MP 0.81	30	24.3	2814	1955	7
129	Ceres Hill MP 7.18	113	24	159	1963	7
130	Curtis Hill MP 3.28	46	24	552	1960	9
131	Burri MP 0.13	60	14	47	1988	*
135	Jackson Hwy MP 4.56	82	36	3427	1926	8
136	Jackson Hwy MP 4.62	82	36	3427	1926	8
137	Jackson Hwy MP 4.67	55	36	3427	1926	8
138	Elk Creek MP 1.56	26	20	183	1952	*
139	Elk Creek MP 2.96	31	14	192	1983	*
141	Beam MP 0.39	33	24	21	1972	*
142	Lech MP 0.24	30	20	9	1953	*
143	Pe Ell Mcdonald MP 6.35	30	21.2	212	1958	12
144	Pe Ell Mcdonald MP 7.31	30	23.8	259	1956	12
145	Roundtree MP 0.29	28	20.4	41	1960	*
146	Lost Valley MP 0.83	30	20	124	1953	9
147	King MP 12.26	46	26	148	1960	2
148	Cook MP 0.07	55	16	13	1994	*
149	King MP 1.59	31	20.8	235	1958	9
150	Coma MP 1.89	46	24	66	1960	3
152	Telegraph MP 0.77	23	24	102	1954	8
153	Telegraph MP 0.55	30	24	122	1965	8
154	Minkler MP 0.04	26	24	606	1951	6
155	North Military MP 4.54	40	34	2151	1995	7
156	Antrim MP 0.57	30	20	324	1958	3
158	Coal Creek MP 1.81	30	29.7	1010	1976	12
159	Taylor MP 0.45	30	20.2	80	1954	*
160	Henriot MP 0.48	32	39	349	1975	5
161	Pleasant Valley MP 2.46	32	28	490	1982	5
162	Pleasant Valley MP 2.91	53	28	490	1987	5
163	Berry MP 1.91	55	16.2	26	1994	*
164	Pleasant Valley MP 5.45	80	32	474	1975	2
165	Brown West MP 0.34	28	25	235	1950	1
166	Brown West MP 0.11	28	18.1	235	1950	1
167	Haywire MP 2.80	24	24	168	1963	5
168	Pigeon Springs MP 0.50	21	28.3	69	2019	*
169	Middle Fork MP 7.07	24	27.4	482	2019	4
170	Snyder MP 0.20	21	29	212	2020	*



Bridge	Bridge Name	Length-Ft	Curb to Curb	Traffic	Year Built	Detour Length
171	Scheuber MP 3.45	29	30	931	1978	11
172	Sargent MP 1.33	74	28	581	1972	5
173	Magnus MP 0.10	40	28	36	1985	*
174	Stover MP 0.03	68	24	42	1967	*
176	Cedar Creek MP 1.87	59	30	63	1977	*
177	Silverbrook MP 4.07	52	28	95	1975	3
178	Nicholson MP 0.45	33	24	98	1972	*
179	Graf MP 1.01	62	28.8	480	2020	1
180	Collins MP 0.48	30	24	255	1962	3
183	Stowell MP 1.42	32	24	332	1960	6
185	Baker MP 0.58	112	20	23	1936	1
186	Baker MP 0.70	72	20	18	1936	*
187	Jackson Hwy MP 12.36	27	36	985	1926	8
188	Schmit MP 1.73	65	20.5	22	1953	*
189	Jackson Hwy MP 12.40	27	36	985	1926	8
190	Toledo Salmon Ck MP 3.33	87	14	31	1977	*
191	Jackson Hwy MP 12.12	27	36	936	1926	8
192	Jackson Hwy MP 14.00	48	30	932	1926	8
193	Skate Creek S. MP 0.45	92	26.6	1359	1955	75
194	Walker MP 0.68	24	20	76	1957	3
196	Mandy MP 2.02	78	20	142	1953	4
197	Spencer MP 5.38	24	28.2	384	1958	9
198	Tucker MP 0.01	33	32	1205	1974	9
199	Leonard MP 2.52	32	26	1725	1962	4
200	Frase MP 0.22	53	19.2	4	1967	*
201	Oyler MP 3.24	30	24	398	1952	7
203	Panisco MP 0.34	40	24	45	1973	*
204	Cinebar MP 1.33	40	32	482	1975	21
205	Godfrey MP 0.29	23	22	77	2014	2
206	Roundtop MP 0.07	63	28	34	1989	*
207	Mineral Creek MP 0.44	52	24	364	1967	*
209	Wilson MP 0.23	24	20	124	1957	*
210	Salmon Creek MP 0.19	60	20	192	1953	*
211	Anderson MP 0.56	60	24.2	83	1965	5
212	Meade Hill MP 0.61	36	20.5	245	1958	4
214	Cispus MP 3.01	31	24.2	204	1952	5
215	Cline MP 7.86	50	28	31	2000	20
216	Peters MP 0.25	28	24.7	192	1964	8
218	Peters MP 0.72	32	24.2	244	1964	8
219	Peters MP 1.13	83	24.2	244	1964	8



Bridge	Bridge Name	Length-Ft	Curb to Curb	Traffic	Year Built	Detour Length
220	Temple MP 0.35	33	24	53	1990	2
221	Stowell MP 0.57	30	30	325	1955	4
223	Townsend MP 0.22	46	13.2	1	1981	*
224	Kiona MP 0.35	50	24.2	724	1962	8
225	Riffe MP 0.14	30	24	6	1962	*
228	Hwy 603 MP 13.39	119	26	2052	1945	1
229	Hwy 603 MP 0.14	377	28	1552	1991	6

*Denotes detour route not available or greater than 99 miles



[This page is intentionally left blank.]



APPENDIX B

Lewis County, Washington
Commissioner Districts



[This page is intentionally left blank.]

Lewis County, Washington

COMMISSIONER DISTRICTS

Adopted Dec. 21, 2021



This map was created by Lewis County Geographic Information Services. The base map was provided by the Washington State Department of Service. Responsibility for accuracy and digital content belongs to Lewis County GIS Services. No warranty is made for any use of this map. The accuracy of the map has not been verified, and it should not be used for administrative purposes only. The possible discrepancies noted are brought to the attention of Lewis County Geographic Information Services.

Projection: Lambert Conformal Conic
 Datum: 1983 North American Datum
 U.S.G.S. StatePlane Zone 5028

- | | | |
|--|---|--|
|  Commissioner District #1 |  State Road |  Private Road |
|  Commissioner District #2 |  County Road |  Forest Road |
|  Commissioner District #3 |  City Street | |
|  City Limits | | |





Appendix C

Emergency Bridge Inspection Priority Rating



[This page is intentionally left blank.]



Scale: 1 : 160,000

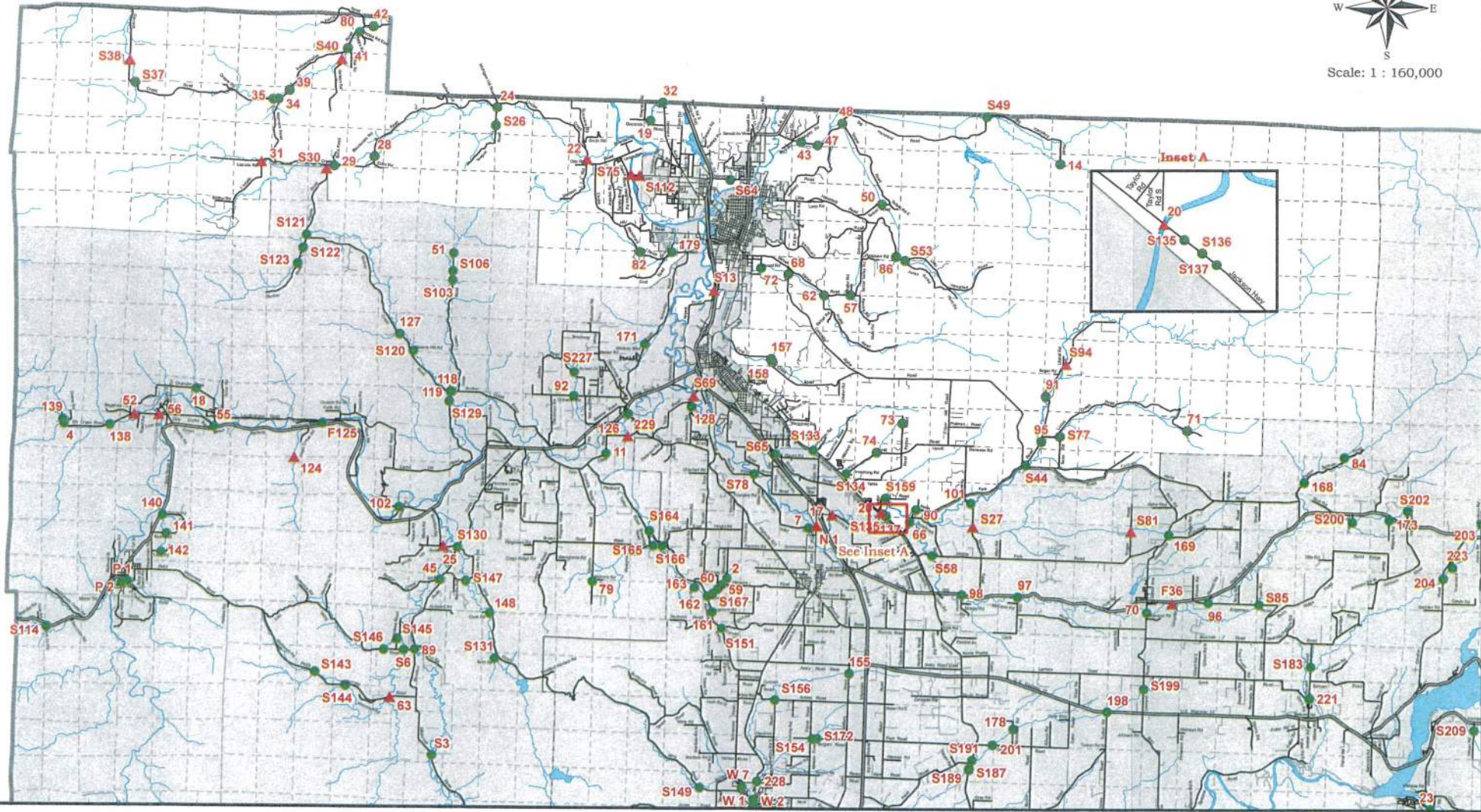

- Earthquake**
 - ▲ High Damage Potential - Priority 1
 - Moderate Damage Potential - Priority 2
- Flood**
 - S = Scour Critical Bridges
- Loading / Special inspection**
 - F = Fracture Critical

Area 1 Bridges Emergency Event Inspections

This map was compiled by Lewis County Geographic Information Services. The accuracy of the map has not been verified and it should be used for reference purposes only.



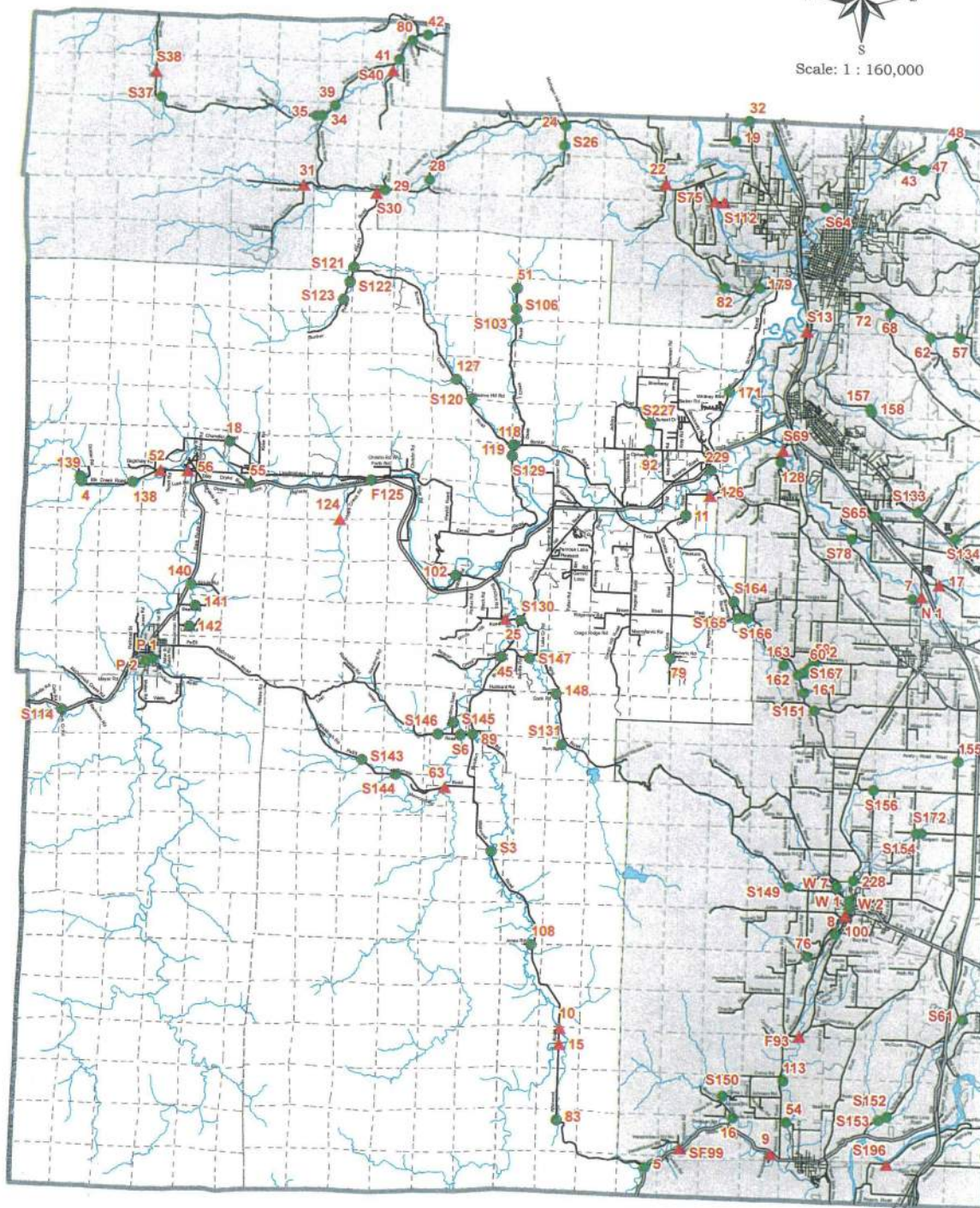

- Earthquake**
- ▲ High Damage Potential - Priority 1
 - Moderate Damage Potential - Priority 2
- Flood**
- S = Scour Critical Bridges
- Loading / Special inspection**
- F = Fracture Critical

Area 2 Bridges

Emergency Event Inspections

This map was compiled by Lewis County Geographic Information Services. The accuracy of the map has not been verified and it should be used for reference purposes only.



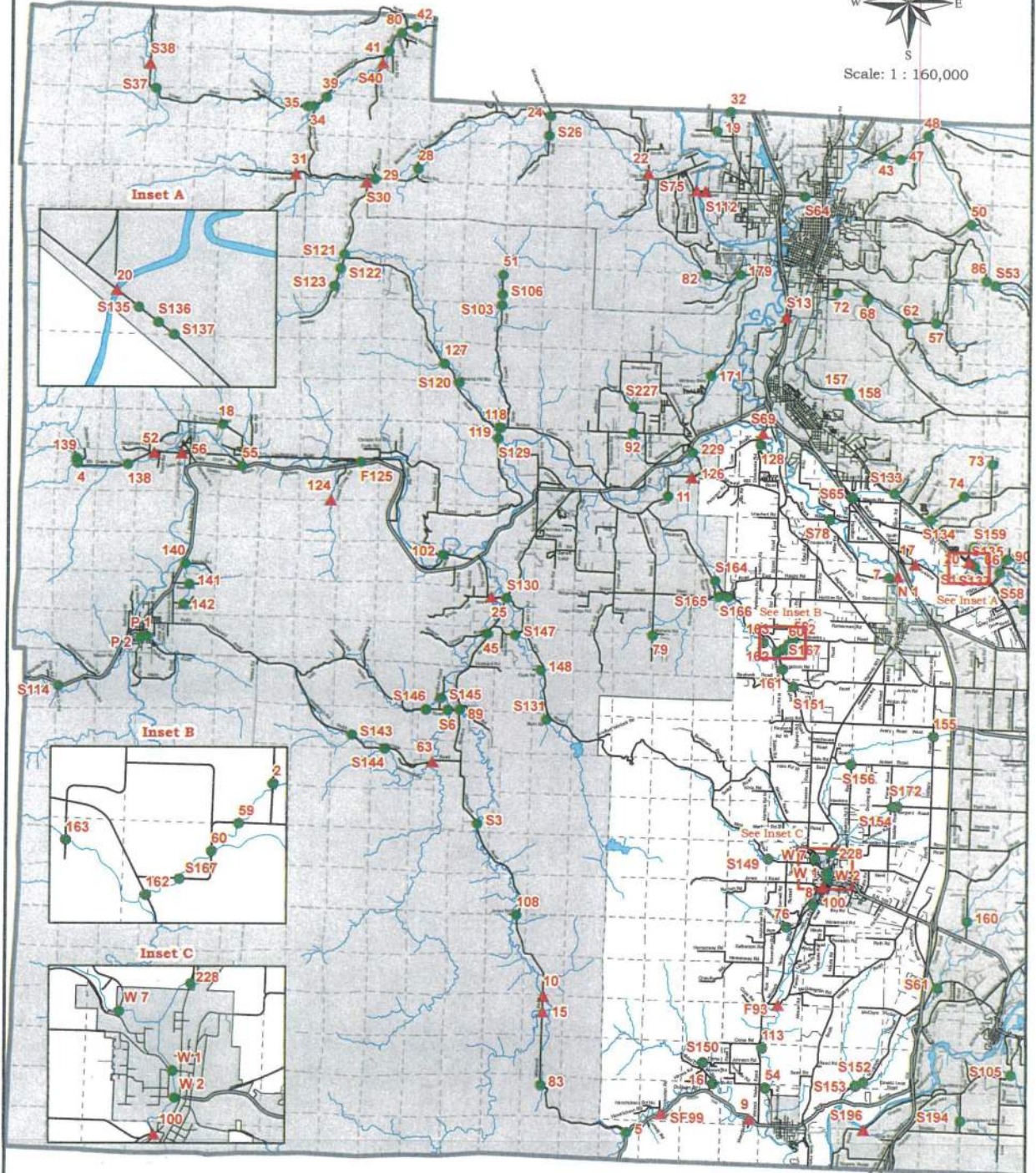
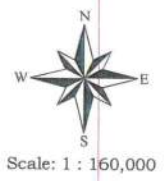

- Earthquake**
- ▲ High Damage Potential - Priority 1
 - Moderate Damage Potential - Priority 2
- Flood**
- S = Scour Critical Bridges
- Loading / Special inspection**
- F = Fracture Critical

Area 3 Bridges

Emergency Event Inspections

This map was compiled by Lewis County Geographic Information Services. The accuracy of the map has not been verified and it should be used for reference purposes only.



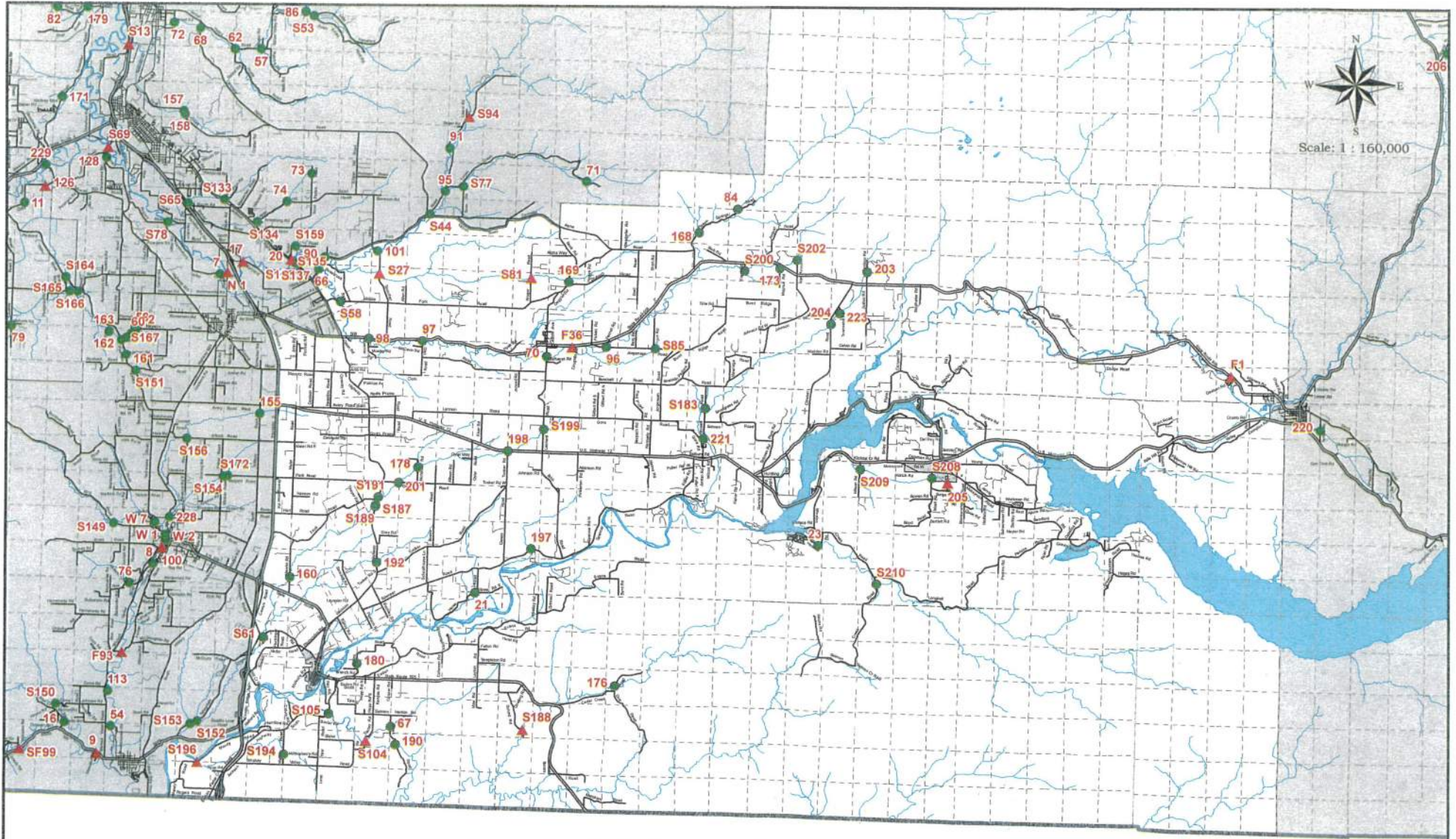

N
W E
S
Scale: 1 : 160,000

- | | |
|---|---|
| <p>Earthquake</p> <ul style="list-style-type: none"> ▲ High Damage Potential - Priority 1 ● Moderate Damage Potential - Priority 2 | <p>Flood</p> <ul style="list-style-type: none"> S = Scour Critical Bridges <p>Loading / Special inspection</p> <ul style="list-style-type: none"> F = Fracture Critical |
|---|---|

Area 5 Bridges Emergency Event Inspections

This map was compiled by Lewis County Geographic Information Services. The accuracy of the map has not been verified and it should be used for reference purposes only.



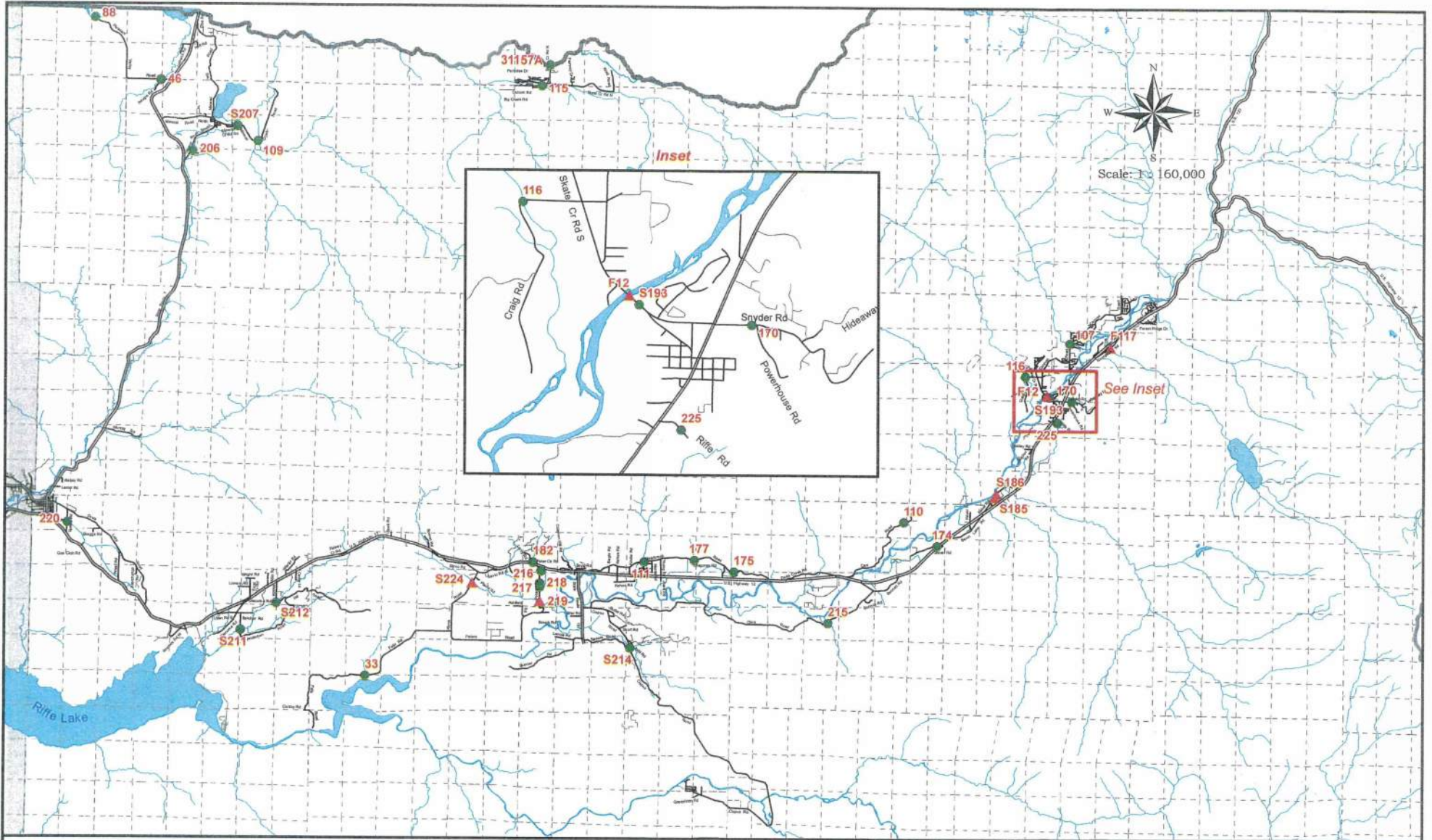

Area 7 Bridges Emergency Event Inspections

- | | |
|---|---|
| <p>Earthquake</p> <ul style="list-style-type: none"> ▲ High Damage Potential - Priority 1 ● Moderate Damage Potential - Priority 2 | <p>Flood</p> <p>S = Scour Critical Bridges</p> <p>Loading / Special inspection</p> <p>F = Fracture Critical</p> |
|---|---|

This map was compiled by Lewis County Geographic Information Services. The accuracy of the map has not been verified and it should be used for reference purposes only.



BRIDGE #	MAINTENANCE AREA 1 BRIDGE NAME	MILE POST	PRIORITY EARTHQUAKE INSPECTIONS	SCOUR CODE	SCOUR CRITICAL / NSTM
13	AIRPORT MP 1.42	1.42	1	U	S
72	ALVORD MP 0.32	0.32	2	5	
43	BIG HANAFORD MP 0.67	0.67	2	8	
47	BIG HANAFORD MP 1.13	1.13	2	5	
48	BIG HANAFORD MP 2.11	2.11	2	5	
49	BIG HANAFORD MP 6.68	6.68	2	U	S
14	BIG HANAFORD MP 9.50	9.50	2	8	
82	BLANCHARD MP 0.87	0.87	2	5	
68	CENTRALIA ALPHA MP 0.17	0.17	2	5	
44	CENTRALIA ALPHA MP 10.03	10.03	2	3	S
157	COAL CREEK MP 1.72	1.72	2	8	
158	COAL CREEK MP 1.81	1.81	2	5	
112	GALVIN MP 1.23	1.23	1	3	S
75	GALVIN MP 1.55	1.55	1	3	S
34	GARRARD CREEK MP 0.07	0.07	2	5	
35	GARRARD CREEK MP 0.22	0.22	2	5	
37	GARRARD CREEK MP 4.35	4.35	2	U	S
38	GARRARD CREEK MP 5.09	5.09	1	U	S
19	GOODRICH MP 0.50	0.50	2	5	
179	GRAF MP 1.01	1.01	2	5	
32	HARRISON AVE MP 2.54	2.54	2	5	
80	HYPPA MP 0.01	0.01	2	5	
39	INDEPENDENCE MP 0.33	0.33	2	5	
42	INDEPENDENCE MP 3.42	3.42	2	5	
133	JACKSON HWY MP 1.96	1.96	2	U	S
20	JACKSON HWY MP 4.49	4.49	1	5	
135	JACKSON HWY MP 4.56	4.56	2	U	S
136	JACKSON HWY MP 4.62	4.62	2	U	S
137	JACKSON HWY MP 4.67	4.67	2	U	S
41	JYLHA MP 0.01	0.01	2	5	
22	LINCOLN CREEK MP 1.02	1.02	1	5	
31	LINCOLN CREEK MP 11.91	11.91	2	8	
28	LINCOLN CREEK MP 8.57	8.57	2	5	
29	LINCOLN CREEK MP 9.83	9.83	2	5	
86	LITTLE HANAFORD MP 5.08	5.08	2	8	
53	LITTLE HANAFORD MP 5.35	5.35	2	U	S
134	LOGAN HILL MP 0.10	0.10	2	U	S
74	LOGAN HILL MP. 1.10	1.10	2	5	
71	LUCAS CREEK MP 5.17	5.17	2	8	
40	NELSON MP 0.16	0.16	1	U	S
66	NORTH FORK MP 0.35	0.35	2	5	
90	NORTH FORK MP 0.70	0.70	2	8	
95	NORTH FORK MP 4.83	4.83	2	7	S
91	NORTH FORK MP 6.11	6.11	2	5	

BRIDGE #	MAINTENANCE AREA 1 BRIDGE NAME	MILE POST	PRIORITY EARTHQUAKE INSPECTIONS	SCOUR CODE	SCOUR CRITICAL / NSTM
94	NORTH FORK MP 7.19	7.19	1	U	S
73	PATTEE MP 0.82	0.82	2	5	
62	PROFFIT MP 0.05	0.05	2	5	
64	REYNOLDS AVE MP 0.52	0.52	2	U	S
57	SALZER VALLEY MP 3.27	3.27	2	5	
77	SENN MP 0.89	0.89	2	3	S
159	TAYLOR MP 0.45	0.45	2	U	S
24	TEAGUE MP 0.08	0.08	2	5	
26	TEAGUE MP 0.57	0.57	2	U	S
50	TEITZEL MP 0.79	0.79	2	5	
(bold Type) Priority inspection of a seismic or major flood event					
Updated on 8-3-22					

BRIDGE #	MAINTENANCE AREA 2 BRIDGE NAME	MILE POST	PRIORITY EARTHQUAKE INSPECTIONS	SCOUR CODE	SCOUR CRITICAL / NSTM
141	BEAM MP 0.39	0.39	2	5	
45	BEAVER CREEK MP 0.02	0.02	2	5	
25	BOISTFORT MP 1.09	1.09	1	5	
89	BOISTFORT MP 4.59	4.59	2	7	S
166	BROWN WEST MP 0.11	0.11	2	U	S
165	BROWN WEST MP 0.34	0.34	2	U	S
118	BUNKER CREEK MP 3.46	3.46	2	5	
119	BUNKER CREEK MP 3.50	3.50	2	5	
127	BUNKER CREEK MP 5.95	5.95	2	5	
122	BUNKER MP 0.26	0.26	2	U	S
123	BUNKER MP 0.71	0.71	2	U	S
131	BURRI MP 0.13	0.13	2	3	S
102	CERES HILL MP 0.79	0.79	2	7	S
129	CERES HILL MP 7.18	7.18	2	3	S
55	CHANDLER MP 0.06	0.06	1	8	
18	CHANDLER MP 1.37	1.37	2	5	
92	CHILVERS MP 1.55	1.55	2	5	
148	COOK MP 0.07	0.07	2	8	
79	COUSINS MP 3.15	3.15	2	5	
130	CURTIS HILL MP 3.28	3.28	2	3	S
103	DEEP CREEK MP 3.18	3.18	2	3	S
106	DEEP CREEK MP 3.44	3.44	2	3	S
51	DEEP CREEK MP 3.93	3.93	2	8	
56	ELK CREEK MP 0.18	0.18	1	5	
52	ELK CREEK MP 0.85	0.85	1	5	
138	ELK CREEK MP 1.56	1.56	2	5	
4	ELK CREEK MP 2.84	2.84	2	5	
139	ELK CREEK MP 2.96	2.96	2	5	
124	HOPE CREEK MP 0.94	0.94	1	5	
229	HWY 603 MP 0.14	0.14	2	5	
121	INGALLS MP 0.22	0.11	2	U	S
30	INGALLS MP 2.11	2.11	1	U	S
227	JEFFRIES MP 0.85	0.85	2	U	S
108	JONES MP 0.06	0.06	2	8	
140	KATULA MP 0.05	0.05	2	5	
147	KING MP 12.26	12.26	2	3	S
142	LECH MP 0.24	0.24	2	5	
6	LOST VALLEY MP 0.29	0.29	2	3	S
146	LOST VALLEY MP 0.83	0.83	2	U	S
125	MAYS BRIDGE MP 0.05	0.05	2	8	NSTM
143	PE ELL MCDONALD MP 6.35	6.35	2	U	S
144	PE ELL MCDONALD MP 7.31	7.31	2	U	S
63	PE ELL MCDONALD MP 8.68	8.68	1	7	S
164	PLEASANT VALLEY MP 5.45	5.45	2	3	S

BRIDGE #	MAINTENANCE AREA 2 BRIDGE NAME	MILE POST	PRIORITY EARTHQUAKE INSPECTIONS	SCOUR CODE	SCOUR CRITICAL / NSTM
114	ROCK CREEK MP 0.03	0.03	2	3	S
145	ROUNDTREE MP 0.29	0.29	2	U	S
171	SCHEUBER MP 3.45	3.45	2	8	
120	STEARNS HILL MP 0.08	0.08	2	3	S
126	TWIN OAKS MP 0.32	0.32	1	5	
11	TWIN OAKS MP 1.37	1.37	2	5	
3	WILDWOOD MP 10.14	10.14	2	3	S
83	WILDWOOD MP 2.99	2.99	2	5	
15	WILDWOOD MP 4.81	4.81	1	5	
10	WILDWOOD MP 5.19	5.19	1	8	
(bold Type) Priority inspection of a seismic or major flood event					
Updated on 8-3-22					

BRIDGE #	MAINTENANCE AREA 3 BRIDGE NAME	MILE POST	PRIORITY EARTHQUAKE INSPECTIONS	SCOUR CODE	SCOUR CRITICAL / NSTM
76	ANDERSON MP 0.05	0.05	2	5	
54	ANNONEN MP 0.14	0.14	2	8	
156	ANTRIM MP 0.57	0.57	2	U	S
163	BERRY MP 1.91	1.91	2	5	
65	BISHOP MP 1.54	1.54	2	U	S
16	BRIM CREEK MP 0.23	0.23	2	5	
150	COMA MP 1.89	1.89	2	U	S
151	CONRAD MP 1.98	1.98	2	3	S
93	FERRIER MP 3.49	3.49	1	5	NSTM
59	HAYWIRE MP 2.40	2.40	1	5	
60	HAYWIRE MP 2.55	2.55	1	5	
167	HAYWIRE MP 2.80	2.80	2	U	S
99	HENDRICKSON MP 0.03	0.03	1	3	S/NSTM
8	HINING MP 0.23	0.23	2	5	
2	HOLCOMB MP 0.81	0.81	1	5	
228	HWY 603 MP 13.39	13.39	2	5	
149	KING MP 1.59	1.59	2	U	S
17	KIRKLAND MP 0.31	0.31	1	7	S
113	KOLLOCK MP 0.19	0.19	2	5	
78	LABREE MP 1.18	1.18	2	3	S
9	MASCHKE MP 0.03	0.03	1	8	
154	MINKLER MP 0.04	0.04	2	U	S
7	NEWAUKUM VALLEY MP 2.38	2.38	2	5	
155	NORTH MILITARY MP 4.54	4.54	2	8	
161	PLEASANT VALLEY MP 2.46	2.46	2	5	
162	PLEASANT VALLEY MP 2.91	2.91	2	8	
172	SARGENT MP 1.33	1.33	2	3	S
69	SHOREY MP 0.48	0.48	1	U	S
128	SHOREY MP 0.81	0.81	2	7	S
153	TELEGRAPH MP 0.55	0.55	2	U	S
152	TELEGRAPH MP 0.77	0.77	2	U	S
5	WILDWOOD MP 0.05	0.05	2	5	
100	WINLOCK VADER MP 0.26	0.26	1	5	
(bold Type) Priority inspection of a seismic or major flood event					
Updated on 8-3-22					

BRIDGE #	MAINTENANCE AREA 5 BRIDGE NAME	MILE POST	PRIORITY EARTHQUAKE INSPECTIONS	SCOUR CODE	SCOUR CRITICAL / NSTM
176	CEDAR CREEK MP 1.87	1.87	2	5	
204	CINEBAR MP 1.33	1.33	2	5	
180	COLLINS MP 0.48	0.48	2	5	
36	COUGHLIN MP 0.05	0.05	1	5	NSTM
1	DAVISON MP 0.01	0.01	1	8	NSTM
61	DREWS PRAIRIE MP 1.21	1.21	2	U	S
200	FRASE MP 0.22	0.22	2	3	S
97	GISH MP 0.03	0.03	2	8	
205	GODFREY M P 0.29	0.29	2	5	
98	GUERRIER MP 0.01	0.01	2	8	
23	HADALLER MP 0.42	0.42	2	5	
160	HENRIOT MP 0.48	0.48	2	5	
21	HOWE MP 2.60	2.60	2	5	
208	ISBELL MP 0.17	0.17	2	U	S
191	JACKSON HWY MP 12.12	12.12	2	U	S
187	JACKSON HWY MP 12.36	12.36	2	U	S
189	JACKSON HWY MP 12.40	12.40	2	U	S
192	JACKSON HWY MP 14.00	14.00	2	5	
105	JACKSON HWY SO. MP 1.01	1.01	2	3	S
96	JORGENSEN MP 0.45	0.45	2	5	
85	JORGENSEN MP 1.82	1.82	2	U	S
81	KRUGER MP 0.69	0.69	1	U	S
70	LEONARD MP 0.32	0.32	2	5	
199	LEONARD MP 2.52	2.52	2	U	S
173	MAGNUS MP 0.10	0.10	2	5	
196	MANDY MP 2.02	2.02	1	U	S
58	MIDDLE FORK MP 0.41	0.41	2	3	S
169	MIDDLE FORK MP 7.07	7.07	2	5	
178	NICHOLSON MP 0.45	0.45	2	5	
201	OYLER MP 3.24	3.24	2	7	S
203	PANISCO MP 0.34	0.34	2	8	
168	PIGEON SPRINGS MP 0.50	0.50	2	5	
84	PIGEON SPRINGS MP 1.95	1.95	2	5	
210	SALMON CREEK MP 0.19	0.19	2	U	S
188	SCHMIT MP 1.73	1.73	1	3	S
197	SPENCER MP 5.38	5.38	2	5	
221	STOWELL MP 0.57	0.57	2	7	S
183	STOWELL MP 1.42	1.42	2	U	S
27	TAUSCHER MP 1.99	2.00	1	U	S
101	TAUSCHER MP 2.64	2.65	2	8	
67	TOLEDO SALMON CK MP 2.74	2.74	2	8	
190	TOLEDO SALMON CK MP 3.33	3.33	2	7	S
104	TOOLEY MP 0.84	0.84	1	3	S
223	TOWNSEND MP 0.22	0.22	2	5	

BRIDGE #	MAINTENANCE AREA 5 BRIDGE NAME	MILE POST	PRIORITY EARTHQUAKE INSPECTIONS	SCOUR CODE	SCOUR CRITICAL / NSTM
198	TUCKER MP 0.01	0.01	2	5	
202	VAN HOESEN MP 0.43	0.43	2	U	S
194	WALKER MP 0.68	0.68	2	U	S
209	WILSON MP 0.23	0.23	2	U	S
(bold Type) Priority inspection of a seismic or major flood event					
Updated on 8-3-22					

BRIDGE #	MAINTENANCE AREA 7 BRIDGE NAME	MILE POST	PRIORITY EARTHQUAKE INSPECTIONS	SCOUR CODE	SCOUR CRITICAL / NSTM
211	ANDERSON MP 0.56	0.56	2	3	S
185	BAKER MP 0.58	0.58	1	3	S
186	BAKER MP 0.70	0.70	1	3	S
107	CANNON MP 2.01	2.01	2	7	S
110	CARR MP 2.74	2.74	2	5	
214	CISPUS MP 3.01	2.07	2	U	S
215	CLINE MP 7.86	7.86	2	5	
116	CRAIG MP 0.48	0.48	2	5	
33	FALLS MP 3.12	3.12	1	9	
224	KIONA MP 0.35	0.35	1	U	S
212	MEADE HILL MP 0.61	0.61	2	U	S
207	MINERAL CREEK MP 0.44	0.44	2	3	S
109	MINERAL CREEK MP 1.21	1.50	1	8	
115	OSBORN MP 0.27	0.27	2	8	
182	PETERS CREEK MP 0.19	0.19	2	5	
216	PETERS MP 0.25	0.25	2	5	
217	PETERS MP 0.62	0.62	2	5	
218	PETERS MP 0.72	0.72	2	5	
219	PETERS MP 1.13	1.13	1	5	
46	PLEASANT VLY EST MP 0.29	0.29	2	8	
88	PLEASANT VLY EST MP 3.45	3.45	2	5	
225	RIFFE MP 0.14	0.14	2	8	
206	ROUNDTOP MP 0.07	0.07	2	8	
111	SILVERBROOK MP 2.61	2.61	2	8	
177	SILVERBROOK MP 4.07	4.07	2	5	
175	SILVERBROOK MP 5.34	5.34	2	5	
12	SKATE CREEK MP 0.53	0.53	1	7	S/NSTM
193	SKATE CREEK S. MP 0.45	0.45	2	U	S
170	SNYDER MP 0.20	0.20	2	5	
174	STOVER MP 0.03	0.03	2	5	
220	TEMPLE MP 0.35	0.35	2	5	
117	THOMPSON ROAD MP 0.55	0.55	1	5	NSTM
(bold Type) Priority inspection of a seismic or major flood event					
Updated on 8-3-22					



Appendix D

Emergency Bridge Inspection and Liquefaction susceptibility



[This page is intentionally left blank.]



Scale: 1 : 160,000

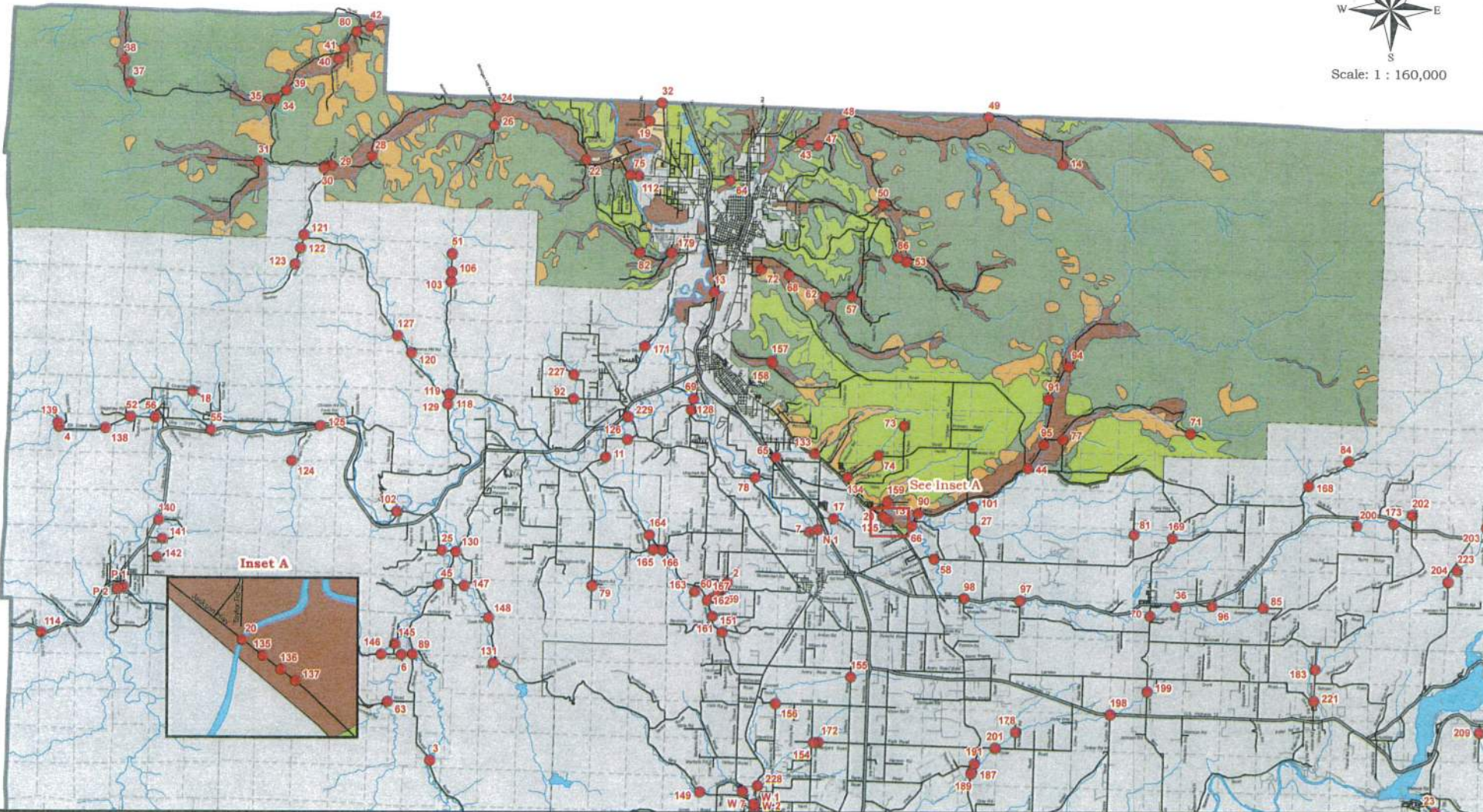

Liquefaction Susceptibility

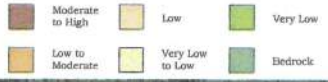

Area 1 Bridges Liquefaction Susceptibility

This map was compiled by Lewis County Geographic Information Services. The accuracy of the map has not been verified and it should be used for reference purposes only.

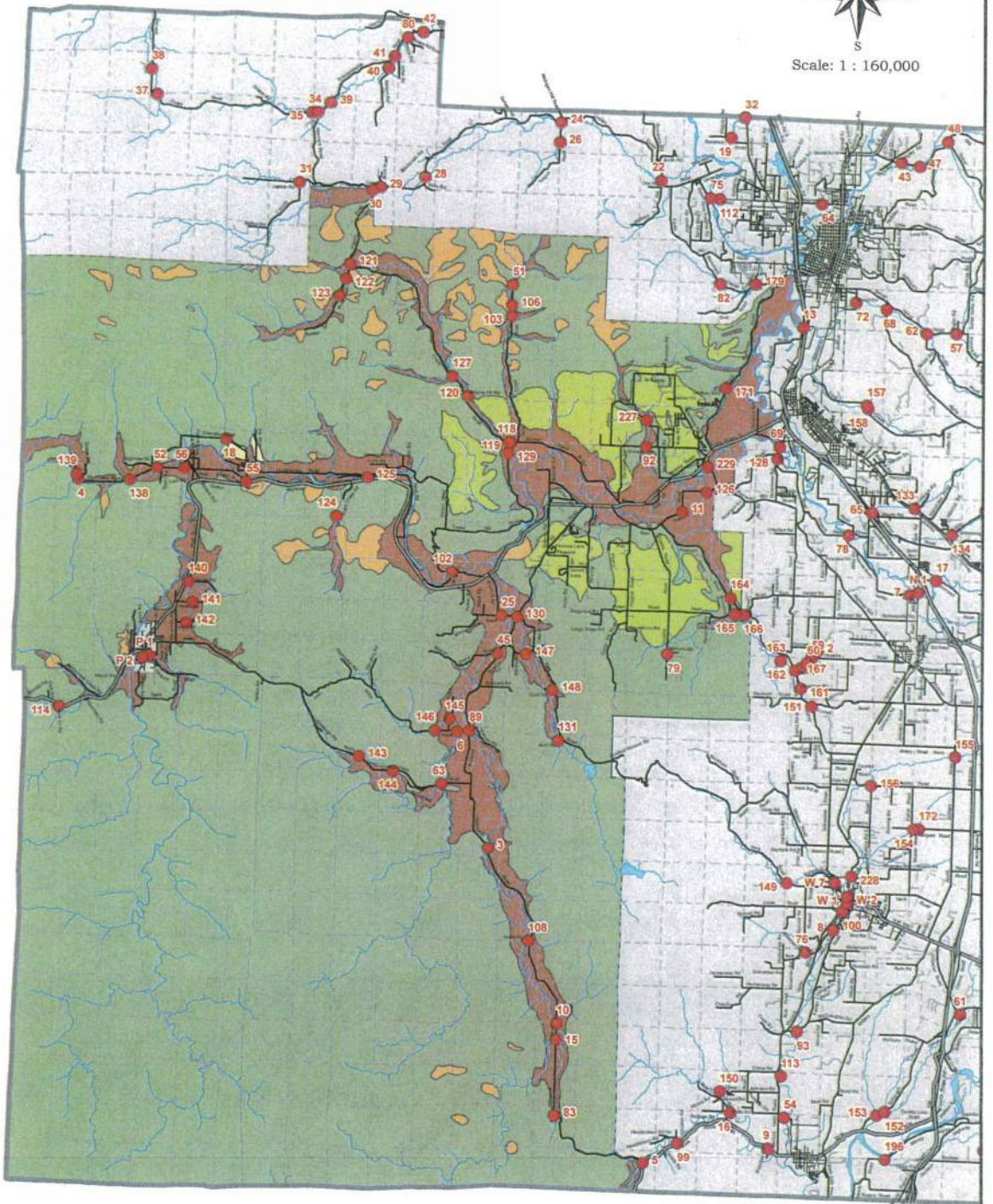

Liquefaction Susceptibility

	Moderate to High		Very Low to Low
	Low to Moderate		Very Low
	Low		Bedrock

Area 2 Bridges

Liquefaction Susceptibility

This map was compiled by Lewis County Geographic Information Services. The accuracy of the map has not been verified and it should be used for reference purposes only.

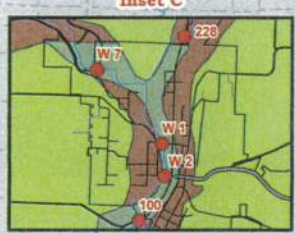
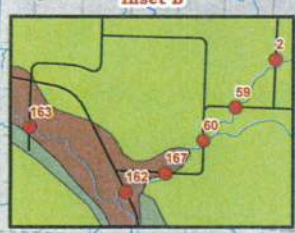
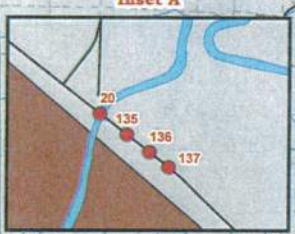
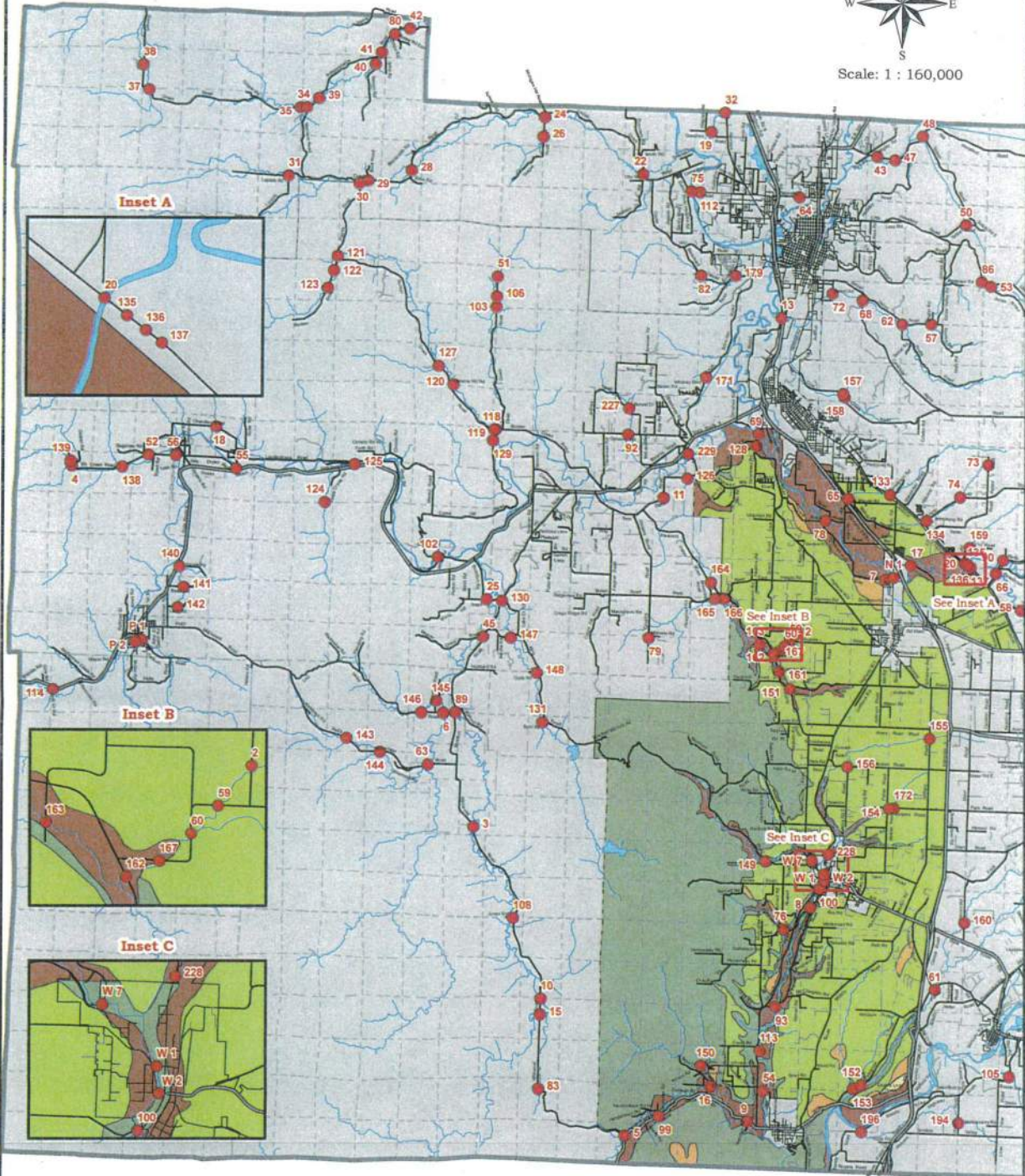

Liquefaction Susceptibility

 Moderate to High	 Very Low to Low
 Low to Moderate	 Very Low
 Low	 Bedrock

Area 3 Bridges





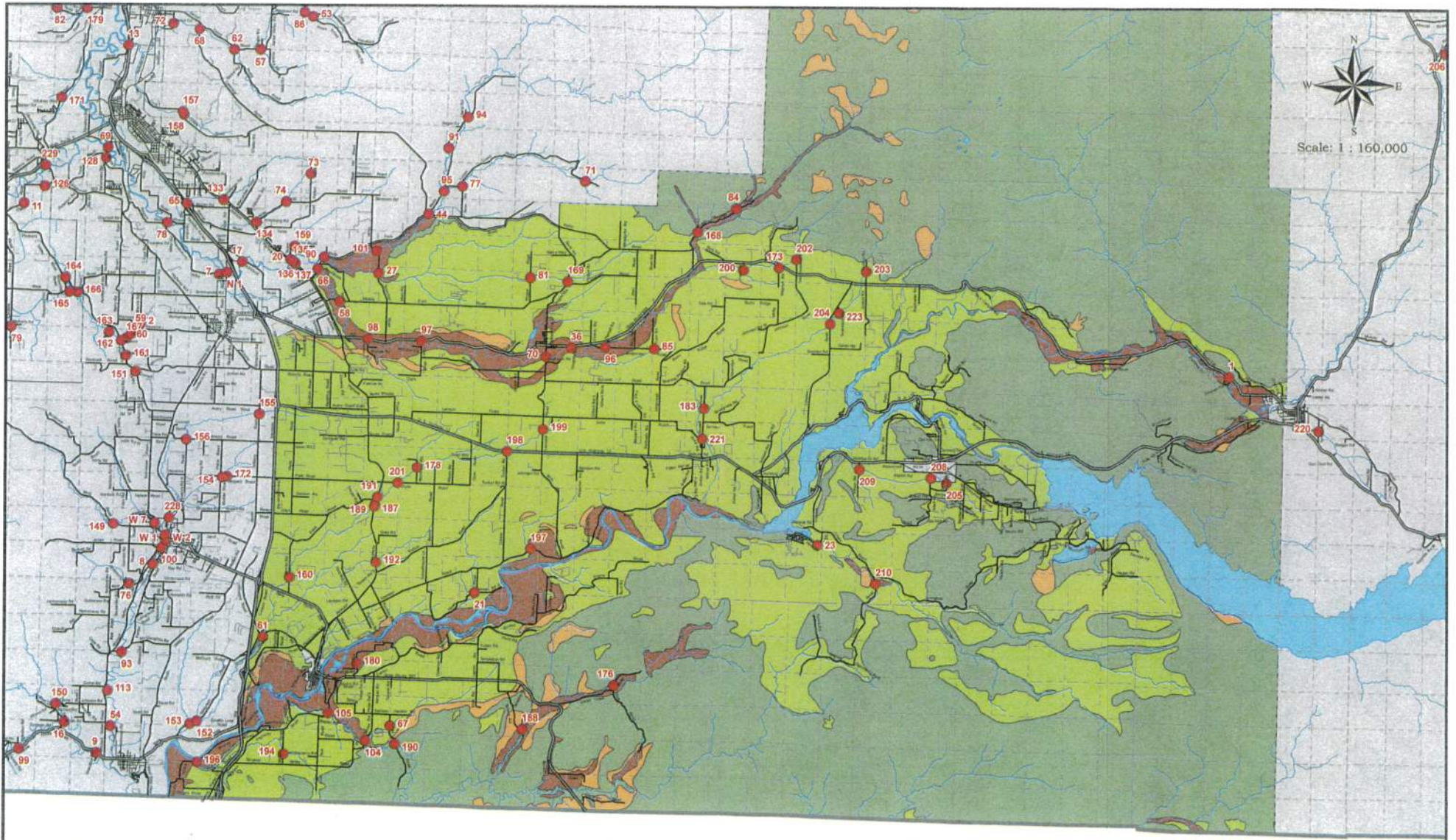

Liquefaction Susceptibility

This map was compiled by Lewis County Geographic Information Services. The accuracy of the map has not been verified and it should be used for reference purposes only.



Scale: 1 : 160,000

Liquefaction Susceptibility

 Moderate to High	 Low	 Very Low
 Low to Moderate	 Very Low to Low	 Bedrock

Area 5 Bridges Liquefaction Susceptibility

This map was compiled by Lewis County Geographic Information Services. The accuracy of the map has not been verified and it should be used for reference purposes only.

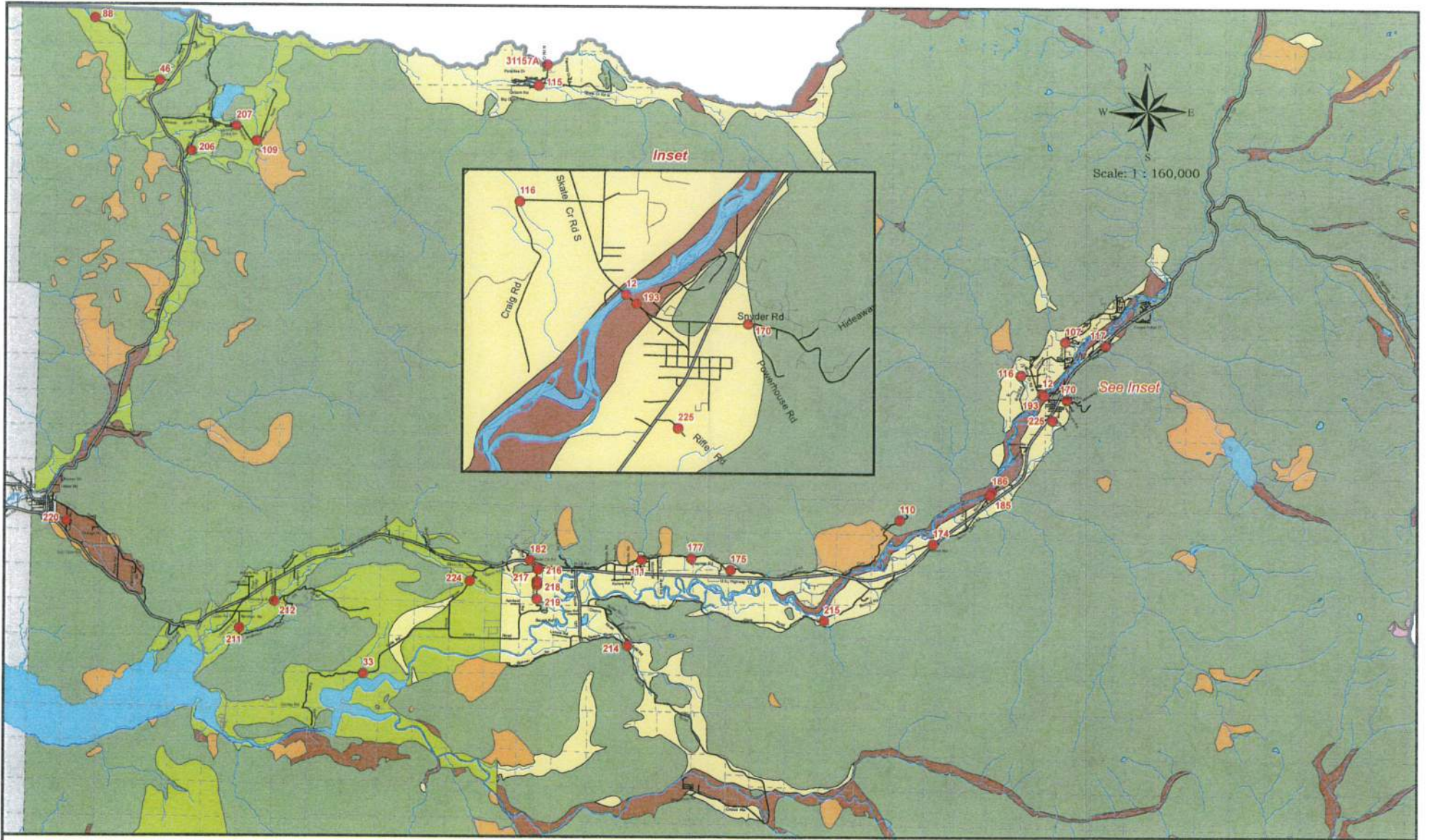

Liquefaction Susceptibility

 Moderate to High	 Low	 Very Low
 Low to Moderate	 Very Low to Low	 Bedrock

Area 7 Bridges Liquefaction Susceptibility

This map was compiled by Lewis County Geographic Information Services. The accuracy of the map has not been verified and it should be used for reference purposes only.